

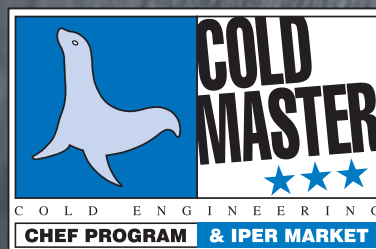

COLD
ENGINEERING
TECFRIGO

CATALOGO GENERALE 2008

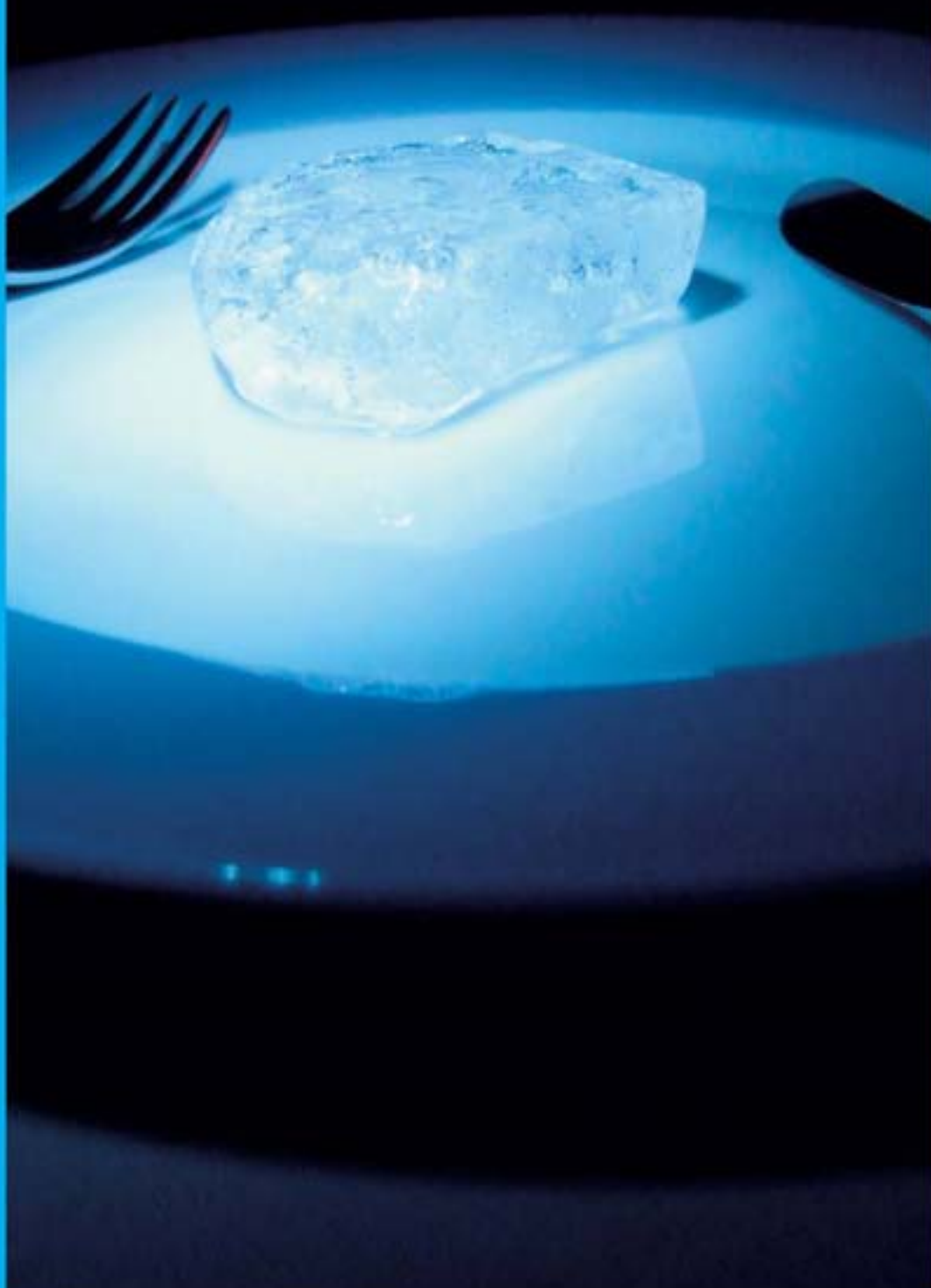

Sommario



1 Euroline

> 1 Littleline	Pag. 6
> 2 Cold Box	Pag. 17
> 3 Penny Line	Pag. 30
> 4 Stock	Pag. 35
> 5 Walking Cooler	Pag. 36

2 Vino

> 1 Bancowine	Pag. 38
> 2 Someliere	Pag. 40

3 Birra

> 1 Distributori	Pag. 46
> 2 Raffreddatori di fusti	Pag. 47
> 3 Chiller	Pag. 49

4 Bar

> 1 Expo Bar	Pag. 54
> 2 Modern Bar	Pag. 55

5 Mercati Speciali

> 1 Break	Pag. 76
> 2 Pocket Bar	Pag. 78
> 3 Travelcold	Pag. 81
> 4 Smaltimento	Pag. 82
> 5 Medikal	Pag. 83

6 Laboratori Pasticceria

> 1 Armadi Sweetline	Pag. 86
> 2 Tavoli Sweetline	Pag. 90

7 Ristorazione

> 1 Snack	Pag. 92
> 2 Kitchen	Pag. 95
> 3 Ecoline	Pag. 101
> 4 Gastroline	Pag. 108
> 5 Fermalievitatori	Pag. 117
> 6 Shockfroster	Pag. 118
> 7 Saladettes	Pag. 122
> 8 Neutro	Pag. 126
> 9 Ice Makers	Pag. 129
> 10 Wash Master	Pag. 133

IL COSTRUTTORE SI RISERVA IL DIRITTO DI APPORTARE MODIFICHE DI MATERIALI E DI MODELLI SENZA PREAVVISO. I PESI, LE MISURE, ECC. SONO SEMPLICEMENTE FORNITI A TITOLO INDICATIVO E NON IMPEGnano IL COSTRUTTORE. • WE RESERVE THE RIGHT TO MAKE CHANGES EITHER IN THE MATERIALS USED OR IN THE MODELS WITHOUT NOTICE. WEIGHTS, DIMENSIONS ETC. ARE GIVEN PURELY AS AN INDICATION AND THEY DO NOT ENGAGE THE MANUFACTURER. • LE CONSTRUCTEUR SE RÉSERVE LE DROIT D'APPORTER TOUTES MODIFICATIONS UTILES SUR LES COMPOSANTS ET LES MODELES SANS PREAVIS. LES POIDS, LES DIMENSIONS CARACTERISTIQUES SONT SIMPLEMENT FOURNIES A TITRE INDICATIF ET N'ENGAGENT PAS LE CONSTRUCTEUR. • DIE HERSTELLERFIRMA BEHAHLT SICH DAS RECHT VOR, OHNE VORHERIGE BENACHRICHTIGUNG AN MATERIAL UND AUSFUHRUNG AENDERUNGEN VORZUNEHMEN. DIE GEWICHTE UND MASSE SIND HINWEISE UND VERPFLICHTEN NICHT DEN HERSTELLER. • EL CONSTRUCTOR SE RESERVA EL DERECHO DE INTRODUCIR MODIFICACIONES EN LOS MATERIALES Y MODELOS SIN PREAVISO. EL PESO, MEDIDAS, ETC. SON DADAS SIMPLEMENTE A TITULO INFORMATIVO, SIN QUE ESTO OBLIGUE AL CONSTRUCTOR.

EUROLINE

VINO

BIRRA

BAR

MERCATI SPECIALI

LABORATORI PASTICCERIA

RISTORAZIONE

FAST FOOD

PIZZERIA

CUCINA

ESPOSIZIONE

SUPERMERCATI

HYPERMARKET



7 Ristorazione

- > 11 Multispazio Pag. 140
- > 12 Big Store Pag. 142

8 Fast Food

- > 1 Food Simpaty Pag. 150
- > 2 Vulcano Pag. 153
- > 3 Sun Simpaty Pag. 158
- > 4 Food Sprinter Pag. 162
- > 5 Hotplate Pag. 165

9 Pizzeria

- > 1 Impastatrici Pag. 168
- > 2 Stenditrici Pag. 169
- > 3 Armadi Pag. 170
- > 4 Schiacciatrici Pag. 171
- > 5 Bancopizza Pag. 172
- > 6 Tavoli Pag. 179
- > 7 Sovrastrutture Pag. 183
- > 8 Piastre&Forni Pag. 185

10 Cucina

- > 1 Accessori per la cucina Pag. 188
- > 2 Scalda Piatti Pag. 194

11 Esposizione

- > 1 Gastroservice Pag. 196
- > 2 Tapas&Sushi Pag. 200
- > 3 Chef Pag. 208

12 Supermercati

- > 1 Island&Murales Pag. 212
- > 2 Murali Pag. 225
- > 3 Banchi Pag. 238
- > 4 Super Pag. 260
- > 5 Delicious Pag. 262
- > 6 Shopping Pag. 264
- > 7 Oceanus Pag. 267
- > 8 Atlantide Pag. 268

13 Hypermarket

- > 1 Banchi Hyper Pag. 273
- > 2 Isole Hyper Pag. 276
- > 3 Murali Hyper Pag. 278

Legenda Symbols

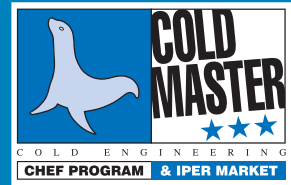

Modello
Model
Modèle
Modell
Modelo



Umidità
Humidity
Hygrométrie
Luftfeuchtigkeit
Humedad



Potenza compressore
Compressor power
Puissance compresseur
Leistung des Kompressors
Potencia compresor



Capacità
Capacity
Capacité
Kapazität
Capacidad

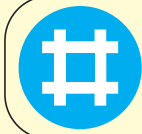

Ripiani a griglia
Grating shelves
Etagères à grille
Gitter-Fächer
Repisas enrejadas

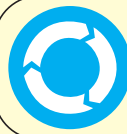

Ripiani rotanti in vetro
Rotating glass shelves
Etagères tournantes en verre
Drehbare Glasfächer
Repisas giratorias de vidrio



Ripiani in cristallo
Crystal plates
Tablettes en cristal
Glasteller
Estantes de cristal

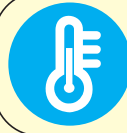

Temperatura
Temperature
Température
Temperatur
Temperatura

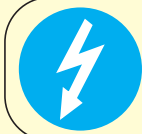

Voltaggio di serie
Standard voltage
Voltage standard
Serienmäßige Spannung
Voltaje en serie



Sbrinamento manuale
Manual defrosting
Dégivrage manuel
Manuelles Abtauen
Descongelación manual



Sbrinamento automatico
Automatic defrosting
Dégivrage automatique
Automatisches Abtauen
Descongelación automática



Refrigerazione agitata
Fan assisted refrigeration
Réfrigération troublée
Geschüttelte Kühlung
Refrigeración estática con pseudo-ventilador



Refrigerazione statica
Static refrigeration
Réfrigération statique
Statische Kühlung
Refrigeración estática



Refrigerazione ventilata
Ventilated refrigeration
Réfrigération ventilée
Belüftete Kühlung
Refrigeración ventilada



Bacinelle
Trays
Cuvettes
Schalen
Bandejas



Gas refrigerante
Cooling gas
Gaz réfrigérant
Kühlgas
Gas refrigerante



Potenze resistenze Bain-Marie
Bain-Marie heating elements power
Puissance des résistances Bain-Marie
Leistung der wasserbadheizkörper
Potencia resistencias Baño María



Peso netto
Net weight
Poids net
Nettogewicht
Peso neto



Vino

EUROLINE

VINO

BIRRA

BAR

MERCATI
SPECIALI

LABORATORI
PASTICCERIA

RISTORAZIONE

FAST FOOD

PIZZERIA

CUCINA

ESPOSIZIONE

SUPERMERCATI

HYPERMARKET

2/1 BANCOWINE

38

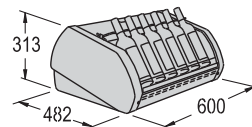

EXPOWINE 6

Espositore per bar e ristoranti facile da posizionare e utilizzare
 Display case for bars and restaurants, easy to position and use /
 Présentoir pour bar et restaurant facile à mettre en place et à utiliser /
 Ausstellingsvitrine für Bar und Restaurant von einfacher Aufstellung und Gebrauch /
 Expositor para bares y restaurantes fácil de colocar y utilizar

Struttura in PVC colore legno scuro
 PVC structure, dark wood colour
 Structure en PVC couleur bois foncé
 Struktur aus dunklem holzfarbigem PVC
 Estructura de PVC color madera oscura

Centralina elettronica
 Electronic cabinet
 Central électronique
 Elektronisches Steuergehäuse
 Centralita electrónica

Area espositiva
 Exhibition area
 Zone d'exposition
 Ausstellungsfläche
 Area expositiva
 0,29 m²

0,75 lt. bottles N° 6



WINECONSOLLE 6

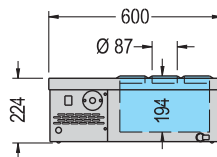

WINECONSOLLE 8

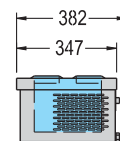
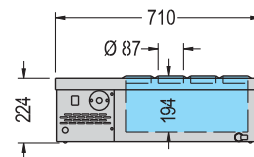



















Diametro bottiglie max. 80 mm.
 Bottles max diameter. 80 mm.
 Diamètre bouteilles maximum 80 mm.
 Flaschendurchmesser maximal. 80 mm.
 Diámetro botellas max. 80 mm.

Selezione della temperatura per vino rosso o bianco / Temperature selection for red and white wines /
 Sélection de la température pour vin rouge ou blanc / Temperaturwahl für Rot- oder Weisswein /
 Selección de la temperatura del vino tinto o blanco

Esterno acciaio inox, interno in alluminio / Inside stainless steel outside aluminium /
 Extérieur en acier inox, intérieur en aluminium / Ausseres aus rostfreiem Stahl, Inneres aus Aluminium /
 Exterior en acero inoxidable, interior en aluminio



Modello Model Modèle Modell Modelo	Potenza Power Puissance Gesamtleistung Potencia	Tensione Tension Tension Spannung Tension	Temperatura Temperature Temperature Temperatur Temperatura	Refrigerazione Refrigeration Refrigeration Kuehlung Refrigeracion	Sbrinatorio Defrosting Degivrage Enteisung Desescarche	Gas refrigerante Cooling gas Gaz réfrigérant Kühlgas Gas refrigerante	Bottiglie bottles Bouteilles Flaschen Botellas	Peso netto Net weight Poids net Nettogewicht Peso neto
 EXPOWINE 6	Watt 190	 230v/1/50Hz	 °C +8/+15			 R 134a	N° 6	Kg 20
 WINECONSOLLE 6	Watt 94	 230v/1/50Hz	 °C +5/+18			 R 134a	N° 6	Kg 16
 WINECONSOLLE 8	Watt 94	 230v/1/50Hz	 °C +5/+18			 R 134a	N° 8	Kg 17



LAMPO 3 (Schockfroster)

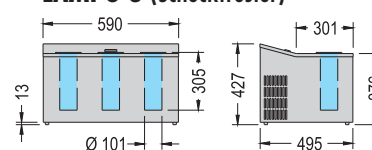

Struttura in lamiera verniciata
 Varnished sheet structure
 Structure en tôle vernie
 Struktur aus lackiertem Blech
 Estructura de chapa pintada

Refrigerazione con liquido antigelo
 Refrigeration with anti freezing liquid
 Réfrigération avec liquide antigel /
 Kühlung mit flüssigen Frost schutzmittel
 Refrigeración con liquido
 anticongelante

Centralina elettronica
 Electronic cabinet
 Central électronique
 Elektronisches Steuergehäuse
 Centralita electrónica

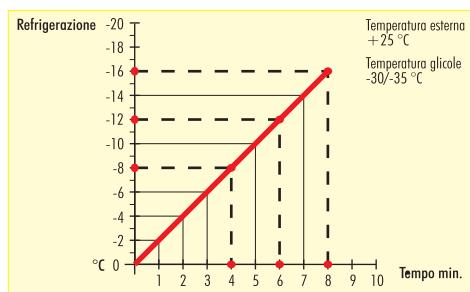

LAMPO 2 (Schockfroster)
 LAMPO 3 (Schockfroster)





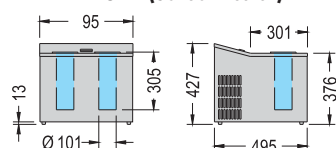

Aspettare che sia acceso da 6-7 ore prima di usarlo, in modo da raggiungere una temperatura di -30°/-35°C. La bottiglia sarà raffreddata ad una velocità di -2°C al minuto.

Before use please wait 6-7 hours functioning, to reach the temperature of -30/-35°C. Bottle will be cooled with speed of -2°C per minute.

Attendre 6-7 heures avant de l'utiliser pour arriver ur temperature de -30/-35°C. La Boueille sera réfrigidis: à une vitesse de -2°C par minute. / das Gerät muss ca 6-7 Stunden angeschaltet sein vor d Benutzung, damit es die Temperatur von -30°/-35° erreichen kann- Die Flasche kuehlt bei einer Geschwindigke von -2°C pro Minute. / Esperar 6-7 horas antes de utilizarlo , para alcanzar temperatura de -30/-35 °C. La botella sera enfriada a ur velocidad de -2 °C por minutos.

LAMPO 2 (Schockfroster)



Modello Model Modèle Modell Modelo	Potenza Power Puissance Gesamtleistung Potencia	Tensione Tension Tension Spannung Tension	Temperatura Temperature Temperature Temperatur Temperatura	Refrigerazione Refrigeration Refrigeration Kuehlung Refrigeracion	Sbrinamento Defrosting Degivrage Enteisung Desescarche	Gas refrigerante Cooling gas Gaz réfrigérant Kühlgas Gas refrigerante	Bottiglie bottles Bouteilles Flaschen Botellas	Peso netto Net weight Poids net Nettogewicht Peso neto
 LAMPO 2 (Schockfroster)	Watt 265	230v/1/50Hz	°C -35			R 134a	N° 2	Kg 32
 LAMPO 3 (Schockfroster)	Watt 300	230v/1/50Hz	°C -35			R 134a	N° 3	Kg 34

Dati di collaudo - Test details - Détails d'essai - Prüfungsergebnisse - Datos de ensayo - MAX = (25°C - % U.R. 60)

EUROLINE
 VINO
 BIRRA
 BAR
 MERCATI SPECIALI
 LABORATORI PASTICCERIA
 RISTORAZIONE
 FAST FOOD
 PIZZERIA
 CUCINA
 ESPOSIZIONE
 SUPERMERCATI
 HYPERMARKET



CVKS 681

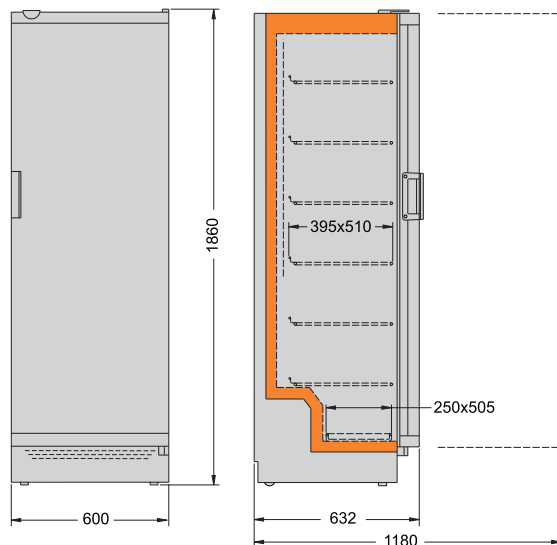

Accessorio optional:
kit ventilazione interna
Optional accessory:
kit internal ventilation /
Accessoire optional:
kit ventilation interne /
Zubehoere Optional:
Umluftkit fuer Innenraum /
Accesorio optional:
Kit ventilacion interior

Evaporazione acqua di sbrinamento
Evaporation of defrost water
Evaporation eau de dégivrage
verdunsten des Auftauwassers
Evaporación agua descongelaçión



0,75 lt. bottles N° 102

Esterno in acciaio verniciato bordeaux. Interno in PVC
Outside made of bordeaux painted steel.
Inside in PVC / Extérieur en acier peint en bordeaux. Intérieur en PVC / Außenfläche aus bordeauxlackiertem Stahl. Innenfläche aus PVC / Externo de acero pintado bordeaux. Interno de PVC



OPTIONAL

Termometro digitale per ripiani in legno
Digital thermometer for wooden shelves
Thermomètre digital pour plateaux en bois
Digitales Thermometer fuer Holzablagen
Termómetro digital por estantes de madera

Modello Model Modèle Modell Modelo	Potenza Power Puissance Gesamtleistung Potencia	Tensione Tension Tension Spannung Tension	Temperatura Temperature Temperatur Temperatur Temperatura	Refrigerazione Refrigeration Refrigeration Kuehlung Refrigeracion	Sbrinamento Defrosting Degivrage Enteisung Desescarche	Gas refrigerante Cooling gas Gaz réfrigérant Kühlgas Gas refrigerante	Capacità Capacity Capacité Gerraumvolumen Capacidad	Ripiani Shelves Clayettes Auflagefläche Repisas	Peso netto Net weight Poids net Nettogewicht Peso neto
CVKS 681	Watt 160	230v/1/50Hz	°C +6/+16			R 134a	Lt. 341	n. 6 mm. 510x395	Kg 62



VKG 581

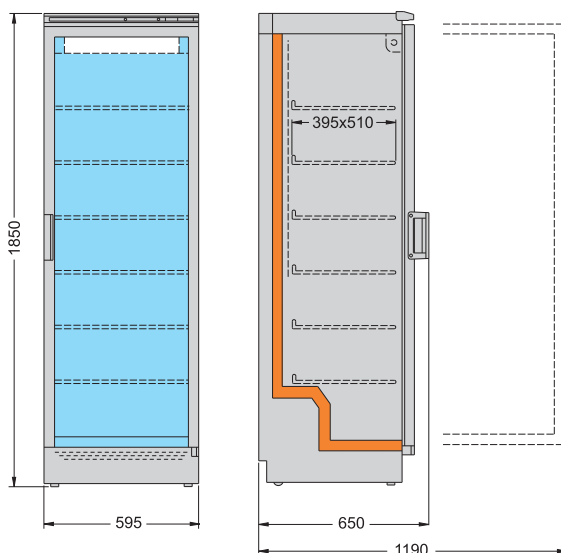

Accessorio optional:
kit ventilazione interna
Optional accessory:
kit internal ventilation /
Accessoire optional:
kit ventilation interne /
Zubehoere Optional:
Umluftkit fuer Innenraum /
Accesorio optional:
Kit ventilacion interior

Evaporazione acqua di sbrinamento
Evaporation of defrost water
Evaporation eau de dégivrage
verdunsten des Auftauwassers
Evaporación agua descongelación



0,75 lt. bottles N° 102

Esterno in acciaio verniciato
bordeaux. Interno in PVC
Outside made of bordeaux painted steel.
Inside in PVC / Extérieur en acier peint
en bordeaux. Intérieur en PVC /
Außenfläche aus bordeauxlackiertem Stahl.
Innenfläche aus PVC / Externo de
acero pintado bordeaux. Interno de PVC



OPTIONAL

Termometro digitale per ripiani in legno
Digital thermometer for wooden shelves
Thermomètre digital pour plateaux en bois
Digitales Thermometer fuer Holzablagen
Termómetro digital por estantes de madera

Modello Model Modèle Modell Modelo	Potenza Power Puissance Gesamtleistung Potencia	Tensione Tension Tension Spannung Tension	Temperatura Temperature Temperature Temperatur Temperatura	Refrigerazione Refrigeration Refrigeration Kuehlung Refrigeracion	Sbrinamento Defrosting Degivrage Enteisung Desescarche	Gas refrigerante Cooling gas Gaz réfrigérant Kühlgas Gas refrigerante	Capacità Capacity Capacité Gerraumvolum Capacidad	Ripiani Shelves Clayettes Auflagefläche Repisas	Peso netto Net weight Poids net Nettogewicht Peso neto
VKG 581 G	Watt 160	230v/1/50Hz	°C +6/+16			R 134a	Lt. 355	n. 6 mm. 510x395	Kg 75

Dati di collaudo - Test details - Détails d'essai - Prüfungsergebnisse - Datos de ensayo - MAX = (30°C - % U.R. 55)

2/2 SOMELIERE

42



Colore bordeaux
bordeaux colour
Couleur bordeaux
Bordeaux Farbe
Color bordeaux

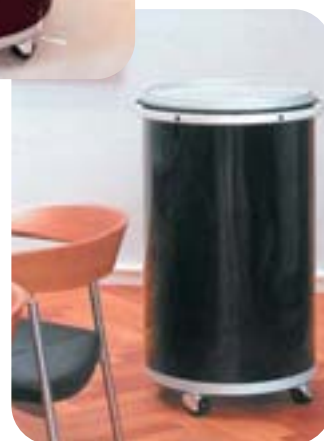

Esterno in lamiera zincata e verniciata. Interno in ABS
Externally made of zinc plated and varnished steel plate. Inside in ABS /
Extérieur en tôle zinguée et vernis.
Intérieur en ABS / Ausseres aus verzinktem und lackiertem Blech.
Innenfläche aus ABS / Exterior en chapa cincada y barnizada. Interno de ABS

Termostato meccanico
Mechanical thermostat
Thermostat mécanique
Mechanischer Temperaturregler
Termostato mecánico

0,50 lt. Pet bottles N° 32
0,33 lt. Cans N° 44

Dimensioni interne
Internal size
Dimensions interne
Innenabmessungen
Dimensiones interiores
h. 400 mm.
Ø 370 mm.

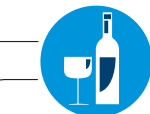
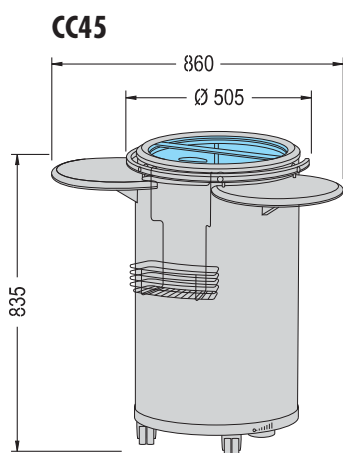

Colore nero
Black colour
Couleur noir
Schwarz Farbe
Color negro

Modello Model Modèle Modell Modelo	Potenza Power Puissance Gesamtleistung Potencia	Tensione Tension Tension Spannung Tension	Temperatura Temperature Temperature Temperatur Temperatura	Refrigerazione Refrigeration Refrigerung Kühlung Refrigeracion	Sbrinatorio Defrosting Degivrage Enteisung Desescarche	Gas refrigerante Cooling gas Gaz réfrigérant Kühlgas Gas refrigerante	Capacità Capacity Capacité Gerraumvolumen Capacidad	Peso netto Net weight Poids net Nettogewicht Peso neto
CC45	Watt 100	230v/1/50Hz	°C +2/+8			R 134a	Lt. 45	Kg 24



VKG 571 BLACK

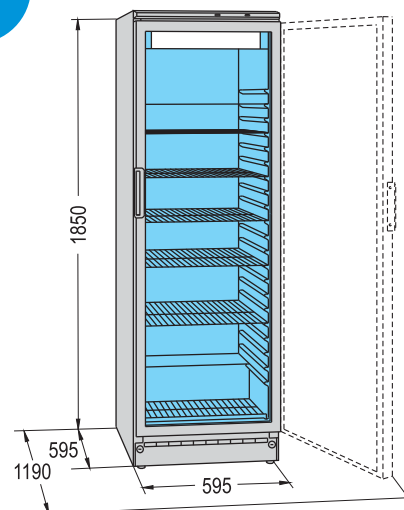

OPTIONAL

Termometro digitale per ripiani in legno
 Digital thermometer for wooden shelves
 Thermomètre digital pour plateaux en bois
 Digitales Thermometer fuer Holzablagen
 Termómetro digital por estantes de madera

Accessorio optional:
 kit ventilazione interna
 Optional accessory:
 kit internal ventilation /
 Accessoire optional:
 kit ventilation interne /
 Zubehoere Optional:
 Umluftkit fuer Innenraum /
 Accesorio optional:
 Kit ventilación interior

Evaporazione acqua di sbrinamento
 Evaporation of defrost water
 Evaporation eau de dégivrage
 verdunsten des Auftauwassers
 Evaporación agua descongelación



0,75 lt. bottles N° 102

Esterno in acciaio verniciato. Interno in PVC
 Painted steel outside. Inside in PVC /
 Extérieur en acier peinté. Intérieur en PVC /
 Aussenseite lackierte Stahl. Innenfläche aus PVC /
 Externo de acero pintado. Interno de PVC

Modello
Model
Modèle
Modell
Modelo

Potenza
Power
Puissance
Gesamtleistung
Potencia

Tensione
Tension
Tension
Spannung
Tension

Temperatura
Temperature
Temperature
Temperatur
Temperatura

Refrigerazione
Refrigeration
Refrigeration
Kuehlung
Refrigeracion

Sbrinamento
Defrosting
Degivrage
Enteisung
Desescarche

Gas refrigerante
Cooling gas
Gaz réfrigérant
Kühlgas
Gas refrigerante

Capacità
Capacity
Capacité
Gerraumvolumen
Capacidad

Ripiani
Shelves
Clayettes
Auflagefläche
Repisas

Peso netto
Net weight
Poids net
Nettogewicht
Peso neto



VKG 571 BLACK

Watt 160

230v/1/50Hz

°C +6/+15



R 134a

Lt. 354

n. 5 mm. 510x395

Kg 75



Evaporazione acqua di sbrinamento
Evaporation of defrost water
Evaporation eau de dégivrage
verdunsten des Auftauwassers
Evaporación agua descongelación



0,75 lt. Bottles N° 32

Esterno in acciaio verniciato. Interno in PVC
Painted steel outside. Inside in PVC / Extérieur en acier peint. Intérieur en PVC / Aussenseite lackierte Stahl. Innenfläche aus PVC / Externo de acero pintado. Interno de PVC

Centralina elettronica
Electronic cabinet
Central électronique
Elektronisches Steuergehäuse
Centralita electrónica

Luce interna
Internal light
Plafonnier
Innenlicht
Luz interior

Serratura
Lock
Serrure
Schloß
Cerradura

C170G BLACK

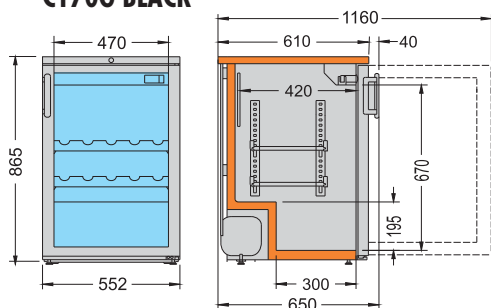

Modello Model Modèle Modell Modelo	Potenza Power Puissance Gesamtleistung Potencia	Tensione Tension Tension Spannung Tension	Temperatura Temperature Temperature Temperatur Temperatura	Refrigerazione Refrigeration Refrigeration Kuehlung Refrigeracion	Sbrinamento Defrosting Degivrage Enteisung Desescarche	Gas refrigerante Cooling gas Gaz réfrigérant Kühlgas Gas refrigerante	Capacità Capacity Capacité Gerraumvolumen Capacidad	Ripiani Shelves Clayettes Auflagefläche Repisas	Peso netto Net weight Poids net Nettogewicht Peso neto
C170G BLACK	Watt 110	230v/1/50Hz	°C +5/+17			R 134a	Lt. 156	n. 3 mm. 470x310	Kg 40

A		
AB	1/2 - COLD BOX	PAG. 24 - 25 - 26
ABX 396	1/2 - COLD BOX	PAG. 27
ABX 506	1/2 - COLD BOX	PAG. 27
ABX 530	1/2 - COLD BOX	PAG. 27
ABX 610	1/2 - COLD BOX	PAG. 27
ABX 710	1/2 - COLD BOX	PAG. 27
ADE C	13/1 - BANCHI HYPER	PAG. 275
ADE M	12/3 - BANCHI	PAG. 246
ADE O	12/3 - BANCHI	PAG. 254
ADI C	13/1 - BANCHI HYPER	PAG. 275
ADI M	12/3 - BANCHI	PAG. 246
ADI O	12/3 - BANCHI	PAG. 254
AE	7/3 - ECOLINE	PAG. 101 - 102 - 103
AE COMBI	7/3 - ECOLINE	PAG. 104 - 105
AFOX 400 FISH	7/1 - SNACK	PAG. 93
ALLU	4/2 - MODERN BAR	PAG. 73
AMERIKA	9/5 - BANCOPIZZA	PAG. 173
AN (Neutro)	7/8 - NEUTRO	PAG. 126 a 128
ANEX 400 NT	7/1 - SNACK	PAG. 92
APEX 400 PT	7/1 - SNACK	PAG. 92
ATE C	13/1 - BANCHI HYPER	PAG. 272
ATE M	12/3 - BANCHI	PAG. 246
ATE O	12/3 - BANCHI	PAG. 254
ATI C	13/1 - BANCHI HYPER	PAG. 272
ATI M	12/3 - BANCHI	PAG. 246
ATI O	12/3 - BANCHI	PAG. 254
AZZURRA 2-3	11/2 - TAPAS&SUSHI	PAG. 207

B		
BABY	12/2 - MURALI	PAG. 228-229
BABY INOX	12/2 - MURALI	PAG. 228-229
BABY WOOD	12/2 - MURALI	PAG. 228-229
BANCO PIZZA PC - P	9/5 - BANCOPIZZA	PAG. 174 a 177
BCG (Chiller)	3/3 - CHILLER	PAG. 49
BE - I (Chiller)	3/3 - CHILLER	PAG. 52
BEG (Chiller)	3/3 - CHILLER	PAG. 50 - 51
BM 1/1-150	10/1 - ACCESS. CUCINA	PAG. 193
BREAK 400-600	5/1 - BREAK	PAG. 76 - 77
BS NT - PTS	7/12 - BIG STORE	PAG. 142 a 144

C		
C 10 G	1/1 - LITTLELINE	PAG. 11
C 10 G SS	1/1 - LITTLELINE	PAG. 11
C 165 G	1/1 - LITTLELINE	PAG. 8
C 170 G BLACK	2/2 - SOMELIERE	PAG. 44
C 2 G	1/1 - LITTLELINE	PAG. 8

C 36 G	1/1 - LITTLELINE	PAG. 6
C 46 G	1/1 - LITTLELINE	PAG. 6
C 5 GM	1/1 - LITTLELINE	PAG. 9
C 61 G	1/1 - LITTLELINE	PAG. 6
C 8 G	1/1 - LITTLELINE	PAG. 10
C 8 G SS	1/1 - LITTLELINE	PAG. 10
C 85 G	1/1 - LITTLELINE	PAG. 7
CARGO	7/4 - GASTROLINE	PAG. 115 - 116
CASSETTIERA 2	9/5 - BANCOPIZZA	PAG. 178
CASSETTIERA 7	9/5 - BANCOPIZZA	PAG. 178
CBX - DELTA	1/2 - COLD BOX	PAG. 18
CBX	1/2 - COLD BOX	PAG. 18
CC 45	2/2 - SOMELIERE	PAG. 42
CC 48	1/1 - LITTLELINE	PAG. 6
CFKS 471 X	1/1 - LITTLELINE	PAG. 16
CFS 344 X	1/1 - LITTLELINE	PAG. 15
CHALLENGER	13/3 - MURALI HYPER	PAG. 278-279
CHALLENGER MAXI	13/3 - MURALI HYPER	PAG. 278-279
CHEF COLD	11/3 - CHEF	PAG. 208
CHEF DRY	11/3 - CHEF	PAG. 210
CHEF TURBO	11/3 - CHEF	PAG. 209
CLEAN DISH	7/10 - WASH MASTER	PAG. 135 a 137
CLEAN GLASS	7/10 - WASH MASTER	PAG. 133 - 134
CLEAN PAN	7/10 - WASH MASTER	PAG. 138 - 139
CLIPPER	12/2 - MURALI	PAG. 226
CREPES	4/2 - MODERN BAR	PAG. 63
CUSTOM CV-SG	13/1 - BANCHI HYPER	PAG. 273
CUSTOM SS-V SG	13/1 - BANCHI HYPER	PAG. 274
CUSTOM CASSA MCC 625	13/1 - BANCHI HYPER	PAG. 274-275
CUTTER 4 - 6	10/1 - ACCESS. CUCINA	PAG. 188
CVKS 681	2/2 - SOMELIERE	PAG. 40
CK - DELTA	1/2 - COLD BOX	PAG. 23
CK	1/2 - COLD BOX	PAG. 23

D		
DELICIOUS	12/5 - DELICIOUS	PAG. 262
DELICIOUS C	12/5 - DELICIOUS	PAG. 262
DELICIOUS SS	12/5 - DELICIOUS	PAG. 262
DELICIOUS Euronorm C	12/5 - DELICIOUS	PAG. 263
DISCOVERY	12/2 - MURALI	PAG. 232
DOLCE	4/2 - MODERN BAR	PAG. 65

E		
EASY	12/2 - MURALI	PAG. 231
EB	3/2 - RAFFRED. DI FUSTI	PAG. 47
EI	7/9 - ICE MAKERS	PAG. 130
EL	1/2 - COLD BOX	PAG. 29

ELBA	12/8 - ATLANTIDE	PAG. 268-269
EM-C 1100 Digit	8/1 - FOOD SIMPATY	PAG. 152
EM-S 1000 Digit	8/1 - FOOD SIMPATY	PAG. 152
EURONORM BASE - VISTA	8/5 - HOTPLATE	PAG. 165
EUROPA	12/1 - ISLAND&MURALES	PAG. 222-223
EXPO WINE	2/1 - BANCOWINE	PAG. 38

✓ **F**

F 165 G	1/1 - LITTLELINE	PAG. 9
F 45 GR	1/1 - LITTLELINE	PAG. 7
FASTFOOD	9/5 - BANCOPIZZA	PAG. 172
FI	7/9 - ICE MAKERS	PAG. 129
FI 13	7/9 - ICE MAKERS	PAG. 129
FIP	7/9 - ICE MAKERS	PAG. 131
FKG 311 S	1/1 - LITTLELINE	PAG. 12
FKG 370 S	1/1 - LITTLELINE	PAG. 14
FKG 371 S	1/1 - LITTLELINE	PAG. 13
FKG	1/2 - COLD BOX	PAG. 17
FKGR	1/2 - COLD BOX	PAG. 17
FMO	8/1 - FOOD SIMPATY	PAG. 150 - 151
FORNETTO PIZZA	4/2 - MODERN BAR	PAG. 55
FP 1	9/8 - PIASTRE&FORNI	PAG. 185
FP 1+1	9/8 - PIASTRE&FORNI	PAG. 185
FP 6	9/8 - PIASTRE&FORNI	PAG. 186
FP 6 BIS	9/8 - PIASTRE&FORNI	PAG. 186
FP 6+6	9/8 - PIASTRE&FORNI	PAG. 186
FP 6+6 BIS	9/8 - PIASTRE&FORNI	PAG. 186
FP 4	9/8 - PIASTRE&FORNI	PAG. 186
FP 4+4	9/8 - PIASTRE&FORNI	PAG. 186
FRAPPE'	4/2 - MODERN BAR	PAG. 70
FRESH YOGURT	4/1 - EXPO BAR	PAG. 54
FRULLATORE TORNADO	4/2 - MODERN BAR	PAG. 70
FRULLATORE TWISTER	4/2 - MODERN BAR	PAG. 69

✓ **G**

GASTRONORM BASE - VISTA	8/5 - HOTPLATE	PAG. 165
GASTROSERVICE COLD	11/1 - GASTROSERVICE	PAG. 196 a 199
GASTROSERVICE DRY	11/1 - GASTROSERVICE	PAG. 196 a 199
GEMINI	8/1 - FOOD SIMPATY	PAG. 150
GENESIS	12/2 - MURALI	PAG. 234
GLX 700	7/4 - GASTROLINE	PAG. 108
GLX 1400	7/4 - GASTROLINE	PAG. 109
GLX FISH	7/4 - GASTROLINE	PAG. 110
GLX COMBI	7/4 - GASTROLINE	PAG. 111
GLX PTS TOP - ALZ	7/4 - GASTROLINE	PAG. 112
GLX NT TOP - ALZ	7/4 - GASTROLINE	PAG. 113
GONDOLA 2V	13/2 - ISOLE HYPER	PAG. 276-277

GONDOLA EXPO	13/2 - ISOLE HYPER	PAG. 276-277
GONDOLA TOP	13/2 - ISOLE HYPER	PAG. 276-277
GONDOLA WALL	13/2 - ISOLE HYPER	PAG. 276-277
GRANSUSHI 3 GN 1/1	11/2 - TAPAS&SUSHI	PAG. 206
GRANTAPAS 3 GN 1/1 - 2	11/2 - TAPAS&SUSHI	PAG. 202
GRANTAPAS 3 GN 1/1 - 2 - SPLIT	11/2 - TAPAS&SUSHI	PAG. 202
GRANTAPAS 3 GN 1/1 BM	11/2 - TAPAS&SUSHI	PAG. 204
GRATIN	4/2 - MODERN BAR	PAG. 59

✓ **H**

HIELO	4/2 - MODERN BAR	PAG. 71
HP 1500 - 2500	4/2 - MODERN BAR	PAG. 56

✓ **I**

ICEBERG	12/1 - ISLAND&MURALES	PAG. 218
IGLOO	12/1 - ISLAND&MURALES	PAG. 216
IKG	1/2 - COLD BOX	PAG. 20
IKG JUMBO	12/1 - ISLAND&MURALES	PAG. 214-215
IKGR	1/2 - COLD BOX	PAG. 20
IL CIOCCO	4/2 - MODERN BAR	PAG. 63
IMPASTA	9/1 - IMPASTATRICI	PAG. 168

✓ **K**

KT 350	7/2 - KITCHEN	PAG. 95 - 96
KTMB PT GLASS	7/2 - KITCHEN	PAG. 97
KTMB PTS - NT	7/2 - KITCHEN	PAG. 98
KTMB COMBI 1.2	7/2 - KITCHEN	PAG. 99
KTMB COMBI 3	7/2 - KITCHEN	PAG. 100

✓ **L**

L 380 - 450	4/2 - MODERN BAR	PAG. 74
LAMPO 2 - 3	2/1 - BANCOWINE	PAG. 39
LC 260 - 300 - 400	10/1 - ACCESS. CUCINA	PAG. 193
LIEVAMATIC 700 NT - PTS	7/5 - FERMALIEVITATORI	PAG. 117
LIEVITA - N	8/3 - SUN SIMPATY	PAG. 161
LIEVITA - S	8/3 - SUN SIMPATY	PAG. 161

✓ **M**

MAJESTIC 45 AE	5/2 - POCKET BAR	PAG. 80
MASTER 45 AE	5/2 - POCKET BAR	PAG. 80
MAXIMA C-BM	12/3 - BANCHI	PAG. 244
MAXIMA CS - CV	12/3 - BANCHI	PAG. 240-241
MAXIMA DS - DV	12/3 - BANCHI	PAG. 240-241
MAXIMA SS-V	12/3 - BANCHI	PAG. 243
MAXIMA HOT	12/3 - BANCHI	PAG. 245
MB 45	5/3 - TRAVELCOLD	PAG. 81
MB 60	5/3 - TRAVELCOLD	PAG. 81

MCS	7/12 - BIG STORE	PAG. 147
MDA	7/12 - BIG STORE	PAG. 145
MDAE	7/12 - BIG STORE	PAG. 146
MEDIKA 300	5/5 - MEDIKAL	PAG. 83
MEDIKA 380	5/5 - MEDIKAL	PAG. 83
MEDIKA 400	5/5 - MEDIKAL	PAG. 84
MEGA 3 - 6	4/2 - MODERN BAR	PAG. 56
MESCOLA 7	10/1 - ACCESS. CUCINA	PAG. 190
MINI AE	5/2 - POCKET BAR	PAG. 78 - 79
MITILI	12/8 - ATLANTIDE	PAG. 268-269
MIXER 430 - 550	10/1 - ACCESS. CUCINA	PAG. 191
MLV	7/12 - BIG STORE	PAG. 148
MCM - BANCO CASSA	12/3 - BANCHI	PAG. 246
MCO - BANCO CASSA	12/3 - BANCHI	PAG. 254
MS 20 - 24	7/11 - MULTISPAZIO	PAG. 140 - 141
MULTI GN - PROF	4/2 - MODERN BAR	PAG. 60 - 61

N

NAXOS	8/3 - SUN SIMPATY	PAG. 160
NEUTRO	7/8 - NEUTRO	PAG. 126 a 128
NV	7/9 - ICE MAKERS	PAG. 130

O

OCEANUS	12/7 - OCEANUS	PAG. 267
OPTIMA BM	12/3 - BANCHI	PAG. 252
OPTIMA CV	12/3 - BANCHI	PAG. 250-251
OPTIMA SS-V	12/3 - BANCHI	PAG. 250-251
OPTIMA HOT	12/3 - BANCHI	PAG. 253
ORION	8/3 - SUN SIMPATY	PAG. 159

P

PANCHO X	4/2 - MODERN BAR	PAG. 62
PANCHO COMBI	4/2 - MODERN BAR	PAG. 62
PE 60 - 90	8/4 - FOOD SPRINTER	PAG. 163
PF 2	8/4 - FOOD SPRINTER	PAG. 162
PIZZA	9/6 - TAVOLI	PAG. 179 a 182
PIZZA 500 PT	9/3 - ARMADI	PAG. 170
PIZZA BASE HOT PLATE	9/8 - PIASTRE&FORNI	PAG. 166
PL 400	1/3 - PENNY LINE	PAG. 31 - 32
PL 500	1/3 - PENNY LINE	PAG. 33
PL 600	1/3 - PENNY LINE	PAG. 34
PLANCHA VULCANO	8/2 - VULCANO	PAG. 155
PLANET	11/2 - TAPAS&SUSHI	PAG. 203 - 205
PM 1 - 2	8/4 - FOOD SPRINTER	PAG. 162
PORTACOOOL	5/3 - TRAVELCOLD	PAG. 81
POS	12/1 - ISLAND&MURALES	PAG. 212
PREMIER	12/2 - MURALI	PAG. 236-237

PROMOXION 130 NT - PT	12/1 - ISLAND&MURALES	PAG. 217
PRONTO PIZZA	4/2 - MODERN BAR	PAG. 55
PRONTO PIZZA BIG	4/2 - MODERN BAR	PAG. 55
PSS 60 - 90	8/4 - FOOD SPRINTER	PAG. 164
PUNTO 1000	12/1 - ISLAND&MURALES	PAG. 213
PUNTO 600	12/1 - ISLAND&MURALES	PAG. 212
PUNTO 700	12/1 - ISLAND&MURALES	PAG. 213

Q

QUICKLY 1200 - 1600	7/4 - GASTROLINE	PAG. 114
----------------------------	------------------	----------

R

RB 300 - 400	1/2 - COLD BOX	PAG. 19
REFRIBIT	4/2 - MODERN BAR	PAG. 68
REP 1 - 2	5/4 - SMALTIMENTO	PAG. 82
RFB	3/2 - RAFFRED. DI FUSTI	PAG. 48
RIBALTA	7/9 - ICE MAKERS	PAG. 132
RISERVA	7/9 - ICE MAKERS	PAG. 131

S

SALAD	7/7 - SALADETTES	PAG. 122 a 125
SCA	7/12 - BIG STORE	PAG. 142
SCAGLIA 250 - 500	7/9 - ICE MAKERS	PAG. 132
SCHIACCIA 35 - 50	9/4 - SCHIACCIATRICI	PAG. 171
SF	7/6 - SHOCKFROSTER	PAG. 120-121
SF 2/3.7-5	7/6 - SHOCKFROSTER	PAG. 120
SFILA M - T	10/1 - ACCESS. CUCINA	PAG. 190
SHOPPING COLD	12/6 - SHOPPING	PAG. 264-265
SHOPPING DRY	12/6 - SHOPPING	PAG. 266
SIRIO	8/3 - SUN SIMPATY	PAG. 158
SKY	12/1 - ISLAND&MURALES	PAG. 219
SKY MASTER	12/1 - ISLAND&MURALES	PAG. 219
SLX PT TOP - ALZ	6/2 - TAVOLI SWETTLINE	PAG. 90
SLX (Armadi)	6/1 - ARMADI SWEETLINE	PAG. 87 - 88 - 89
SLXE 500 GLASS	6/1 - ARMADI SWEETLINE	PAG. 86
SLXE 500 NT	6/1 - ARMADI SWEETLINE	PAG. 86
SLXE 500 PTS	6/1 - ARMADI SWEETLINE	PAG. 86
SMART CS - DS	12/3 - BANCHI	PAG. 238-239
SMART CV - DV	12/3 - BANCHI	PAG. 238-239
SP138 - SP238	10/2 - SCALDA PIATTI	PAG. 194
SP	9/7 - SOVRASTRUTTURE	PAG. 183 - 184
SPACE	12/2 - MURALI	PAG. 233
SPD	9/7 - SOVRASTRUTTURE	PAG. 183 - 184
SPIO	12/2 - MURALI	PAG. 225
SPIO WOOD	12/2 - MURALI	PAG. 225
SPREMIAGRUMI	4/2 - MODERN BAR	PAG. 72
STAR	4/2 - MODERN BAR	PAG. 57 - 58

STENDI 30 - 40	9/2 - STENDITRICI	PAG. 169
STENDI 30 SFO	9/2 - STENDITRICI	PAG. 169
STOCK PT	1/4 - STOCK	PAG. 35
STOCK PTX	1/4 - STOCK	PAG. 35
STONE 190 NT - 250 NT	13/3 - MURALI HYPER	PAG. 281
STORAGE	7/9 - ICE MAKERS	PAG. 132
SUPER	12/4 - SUPER	PAG. 260
SUPER Euronorm C	12/4 - SUPER	PAG. 261
SUSHI	11/2 - TAPAS&SUSHI	PAG. 206
SZ	1/2 - COLD BOX	PAG. 28

T

TAGLIAVERDURE M - T	10/1 - ACCESS. CUCINA	PAG. 189
TAPAS	11/2 - TAPAS&SUSHI	PAG. 200 a 204
TEMPANO	1/3 - PENNY LINE	PAG. 30
TERMOLAT	4/2 - MODERN BAR	PAG. 64
TOASTER TURBO	4/2 - MODERN BAR	PAG. 59
TORNADO	4/2 - MODERN BAR	PAG. 70
TPEX PT ALZ - TOP SG	7/1 - SNACK	PAG. 94
TPEX PT	7/1 - SNACK	PAG. 94
TRICAR	10/1 - ACCESS. CUCINA	PAG. 192
TRIGRA	10/1 - ACCESS. CUCINA	PAG. 192
TRITAGHIACCIO	4/2 - MODERN BAR	PAG. 71
TSC PTS/NT - TOP/ALZ	7/3 - ECOLINE	PAG. 106
TSC PTS/NT - TOP/ALZ SG	7/3 - ECOLINE	PAG. 107
TURBINE INOX	4/2 - MODERN BAR	PAG. 73
TWISTER	4/2 - MODERN BAR	PAG. 69

U

ULISSE	12/2 - MURALI	PAG. 230
ULISSE INOX	12/2 - MURALI	PAG. 230
UNIVERSAL	12/2 - MURALI	PAG. 235

V

V - 30 - 100 - 200	3/1 - DISTRIBUTORI	PAG. 46
V 1 - 2	4/2 - MODERN BAR	PAG. 67
VCI	1/2 - COLD BOX	PAG. 21
VDA	4/2 - MODERN BAR	PAG. 67
VEGA EM	8/1 - FOOD SIMPATY	PAG. 152
VETRINETTA	4/2 - MODERN BAR	PAG. 66
VKG 571 BLACK	2/2 - SOMELIERE	PAG. 43
VKG 581 G	2/2 - SOMELIERE	PAG. 41
VLC	1/2 - COLD BOX	PAG. 22
VODKA 4 - 6	4/1 - EXPO BAR	PAG. 54
VORTICE	4/2 - MODERN BAR	PAG. 68
VOYAGER 200 COMBI	12/1 - ISLAND&MURALES	PAG. 224
VOYAGER 200 COMBI SPECIAL	12/1 - ISLAND&MURALES	PAG. 224
VOYAGER 200 NT - PT	12/1 - ISLAND&MURALES	PAG. 224
VULCANO	8/2 - VULCANO	PAG. 153 a 156
VULCANO MODULO	8/2 - VULCANO	PAG. 157
VULCANO WOK	8/2 - VULCANO	PAG. 155

W

WINE CONSOLE 6 - 8	2/1 - BANCOWINE	PAG. 38
WLK PT - NT	1/5 - WALKING COOLER	PAG. 36

NEWS 2008

IL COSTRUTTORE SI RISERVA IL DIRITTO DI APPORTARE MODIFICHE DI MATERIALI E DI MODELLI SENZA PREAVVISO. I PESI, LE MISURE, ECC., SONO SEMPLICEMENTE FORNITI A TITOLO INDICATIVO E NON IMPEGNANO IL COSTRUTTORE. • WE RESERVE THE RIGHT TO MAKE CHANGES EITHER IN THE MATERIALS USED OR IN THE MODELS WITHOUT NOTICE. WEIGHTS, DIMENSIONS ETC. ARE GIVEN PURELY AS AN INDICATION AND THEY DO NOT ENGAGE THE MANUFACTURER. • LE CONSTRUCTEUR SE RÉSERVE LE DROIT D'APPORTER TOUTES MODIFICATIONS UTILES SUR LES COMPOSANTS ET LES MODELES SANS PRÉAVIS. LES POIDS, LES DIMENSIONS CARACTÉRISTIQUES SONT SIMPLEMENT FOURNIES A TITRE INDICATIF ET N'ENGAGENT PAS LE CONSTRUCTEUR. • DIE HERSTELLERFIRMA BEHAHLT SICH DAS RECHT VOR, OHNE VORHERIGE BENACHRICHTIGUNG AN MATERIAL UND AUSFUEHRUNG AENDERUNGEN VORZUNEHMEN. DIE GEWICHTE UND MASSE SIND HINWEISE UND VERPFLICHTEN NICHT DEN HERSTELLER. • EL CONSTRUCTOR SE RESERVA EL DERECHO DE INTRODUCIR MODIFICACIONES EN LOS MATERIALES Y MODELOS SIN PREAVISO. EL PESO, MEDIDAS, ETC. SON DADAS SIMPLEMENTE A TITULO INFORMATIVO, SIN QUE ESTO OBLIGUE AL CONSTRUCTOR.

EUROLINE
VINO
BIRRA
BAR
MERCATI SPECIALI
LABORATORI PASTICCERIA
RISTORAZIONE
FAST FOOD
PIZZERIA
CUCINA
ESPOSIZIONE
SUPERMERCATI
HYPERMARKET

NOTE

HYPERMARKET

SUPERMERCATI

ESPOSIZIONE

CUCINA

PIZZERIA

FAST FOOD

RISTORAZIONE

LABORATORI
PASTICCERIAMERCATI
SPECIALI

BAR

BIRRA

VINO

EUROLINE

HYPERMARKET

SUPERMERCATI

ESPOSIZIONE

CUCINA

PIZZERIA

FAST FOOD

RISTORAZIONE

LABORATORI
PASTICCERIA

MERCATI
SPECIALI

BAR

BIRRA

VINO

EUROLINE

Note



COLD
ENGINEERING
TECFRIGO



Organizzazione con Sistema
di Gestione certificato
Company with Management
System certified

ISO 9001:2000

SINCERT