

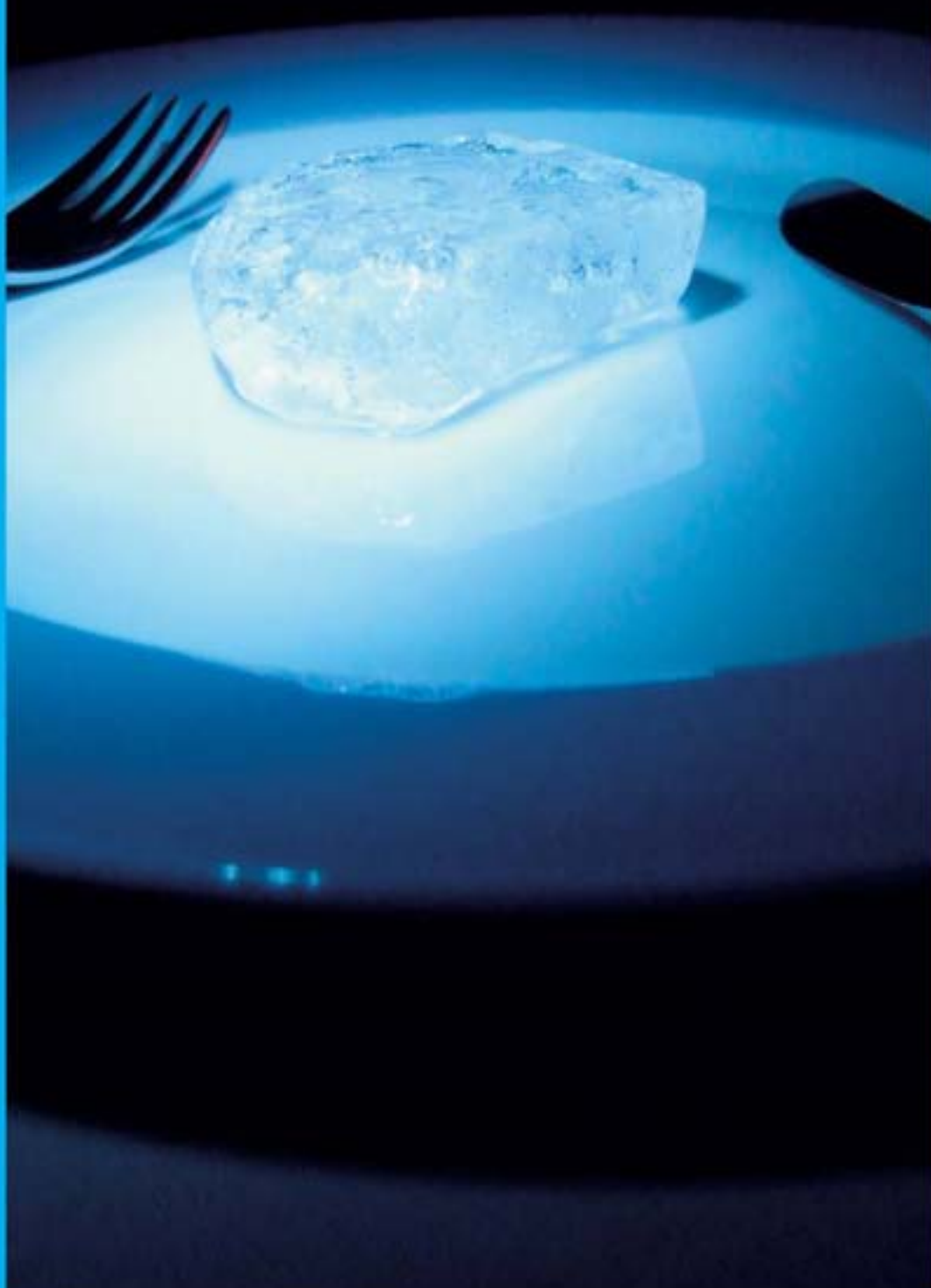

COLD  
ENGINEERING  
**TECFRIGO**

# CATALOGO GENERALE 2008





# Sommario



## 1 Euroline

> 1 Littleline	Pag. 6
> 2 Cold Box	Pag. 17
> 3 Penny Line	Pag. 30
> 4 Stock	Pag. 35
> 5 Walking Cooler	Pag. 36

## 2 Vino

> 1 Bancowine	Pag. 38
> 2 Someliere	Pag. 40

## 3 Birra

> 1 Distributori	Pag. 46
> 2 Raffreddatori di fusti	Pag. 47
> 3 Chiller	Pag. 49

## 4 Bar

> 1 Expo Bar	Pag. 54
> 2 Modern Bar	Pag. 55

## 5 Mercati Speciali

> 1 Break	Pag. 76
> 2 Pocket Bar	Pag. 78
> 3 Travelcold	Pag. 81
> 4 Smaltimento	Pag. 82
> 5 Medikal	Pag. 83

## 6 Laboratori Pasticceria

> 1 Armadi Sweetline	Pag. 86
> 2 Tavoli Sweetline	Pag. 90

## 7 Ristorazione

> 1 Snack	Pag. 92
> 2 Kitchen	Pag. 95
> 3 Ecoline	Pag. 101
> 4 Gastroline	Pag. 108
> 5 Fermalievitatori	Pag. 117
> 6 Shockfroster	Pag. 118
> 7 Saladettes	Pag. 122
> 8 Neutro	Pag. 126
> 9 Ice Makers	Pag. 129
> 10 Wash Master	Pag. 133

IL COSTRUTTORE SI RISERVA IL DIRITTO DI APPORTARE MODIFICHE DI MATERIALI E DI MODELLI SENZA PREAVVISO. I PESI, LE MISURE, ECC. SONO SEMPLICEMENTE FORNITI A TITOLO INDICATIVO E NON IMPEGnano IL COSTRUTTORE. • WE RESERVE THE RIGHT TO MAKE CHANGES EITHER IN THE MATERIALS USED OR IN THE MODELS WITHOUT NOTICE. WEIGHTS, DIMENSIONS ETC. ARE GIVEN PURELY AS AN INDICATION AND THEY DO NOT ENGAGE THE MANUFACTURER. • LE CONSTRUCTEUR SE RÉSERVE LE DROIT D'APPORTER TOUTES MODIFICATIONS UTILES SUR LES COMPOSANTS ET LES MODELES SANS PREAVIS. LES POIDS, LES DIMENSIONS CARACTERISTIQUES SONT SIMPLEMENT FOURNIES A TITRE INDICATIF ET N'ENGAGENT PAS LE CONSTRUCTEUR. • DIE HERSTELLERFIRMA BEHAHLT SICH DAS RECHT VOR, OHNE VORHERIGE BENACHRICHTIGUNG AN MATERIAL UND AUSFUHRUNG AENDERUNGEN VORZUNEHMEN. DIE GEWICHTE UND MASSE SIND HINWEISE UND VERPFLICHTEN NICHT DEN HERSTELLER. • EL CONSTRUCTOR SE RESERVA EL DERECHO DE INTRODUCIR MODIFICACIONES EN LOS MATERIALES Y MODELOS SIN PREAVISO. EL PESO, MEDIDAS, ETC. SON DADAS SIMPLEMENTE A TITULO INFORMATIVO, SIN QUE ESTO OBLIGUE AL CONSTRUCTOR.

EUROLINE  
VINO  
BIRRA  
BAR  
MERCATI SPECIALI  
LABORATORI PASTICCERIA  
RISTORAZIONE  
FAST FOOD  
PIZZERIA  
CUCINA  
ESPOSIZIONE  
SUPERMERCATI  
HYPERMARKET



## 7 Ristorazione

- > 11 Multispazio Pag. 140
- > 12 Big Store Pag. 142

## 8 Fast Food

- > 1 Food Simpaty Pag. 150
- > 2 Vulcano Pag. 153
- > 3 Sun Simpaty Pag. 158
- > 4 Food Sprinter Pag. 162
- > 5 Hotplate Pag. 165

## 9 Pizzeria

- > 1 Impastatrici Pag. 168
- > 2 Stenditrici Pag. 169
- > 3 Armadi Pag. 170
- > 4 Schiacciatrici Pag. 171
- > 5 Bancopizza Pag. 172
- > 6 Tavoli Pag. 179
- > 7 Sovrastrutture Pag. 183
- > 8 Piastre&Forni Pag. 185

## 10 Cucina

- > 1 Accessori per la cucina Pag. 188
- > 2 Scalda Piatti Pag. 194

## 11 Esposizione

- > 1 Gastroservice Pag. 196
- > 2 Tapas&Sushi Pag. 200
- > 3 Chef Pag. 208

## 12 Supermercati

- > 1 Island&Murales Pag. 212
- > 2 Murali Pag. 225
- > 3 Banchi Pag. 238
- > 4 Super Pag. 260
- > 5 Delicious Pag. 262
- > 6 Shopping Pag. 264
- > 7 Oceanus Pag. 267
- > 8 Atlantide Pag. 268

## 13 Hypermatket

- > 1 Banchi Hyper Pag. 273
- > 2 Isole Hyper Pag. 276
- > 3 Murali Hyper Pag. 278

# Legenda Symbols

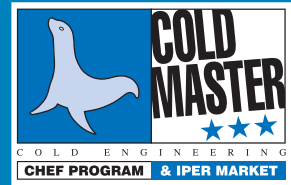

**Modello**  
Model  
Modèle  
Modell  
Modelo



**Umidità**  
Humidity  
Hygrométrie  
Luftfeuchtigkeit  
Humedad



**Potenza compressore**  
Compressor power  
Puissance compresseur  
Leistung des Kompressors  
Potencia compresor



**Capacità**  
Capacity  
Capacité  
Kapazität  
Capacidad

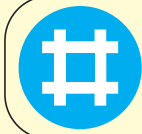

**Ripiani a griglia**  
Grating shelves  
Etagères à grille  
Gitter-Fächer  
Repisas enrejadas

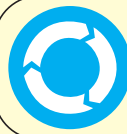

**Ripiani rotanti in vetro**  
Rotating glass shelves  
Etagères tournantes en verre  
Drehbare Glasfächer  
Repisas giratorias de vidrio



**Ripiani in cristallo**  
Crystal plates  
Tablettes en cristal  
Glasteller  
Estantes de cristal

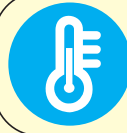

**Temperatura**  
Temperature  
Température  
Temperatur  
Temperatura

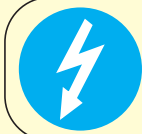

**Voltaggio di serie**  
Standard voltage  
Voltage standard  
Serienmäßige Spannung  
Voltaje en serie



**Sbrinamento manuale**  
Manual defrosting  
Dégivrage manuel  
Manuelles Abtauen  
Descongelación manual



**Sbrinamento automatico**  
Automatic defrosting  
Dégivrage automatique  
Automatisches Abtauen  
Descongelación automática



**Refrigerazione agitata**  
Fan assisted refrigeration  
Réfrigération troublée  
Geschüttelte Kühlung  
Refrigeración estática con pseudo-ventilador



**Refrigerazione statica**  
Static refrigeration  
Réfrigération statique  
Statische Kühlung  
Refrigeración estática



**Refrigerazione ventilata**  
Ventilated refrigeration  
Réfrigération ventilée  
Belüftete Kühlung  
Refrigeración ventilada



**Bacinelle**  
Trays  
Cuvettes  
Schalen  
Bandejas



**Gas refrigerante**  
Cooling gas  
Gaz réfrigérant  
Kühlgas  
Gas refrigerante



**Potenze resistenze Bain-Marie**  
Bain-Marie heating elements power  
Puissance des résistances Bain-Marie  
Leistung der wasserbadheizkörper  
Potencia resistencias Baño María



**Peso netto**  
Net weight  
Poids net  
Nettogewicht  
Peso neto

HYPERMARKET

SUPERMERCATI

ESPOSIZIONE

CUCINA

PIZZERIA

FAST FOOD

RISTORAZIONE

LABORATORI  
PASTICCERIA

MERCATI  
SPECIALI

BAR

BIRRA

VINO

EUROLINE



# Fast Food

HYPERMARKET

SUPERMERCATI

ESPOSIZIONE

CUCINA

PIZZERIA

FAST FOOD

RISTORAZIONE

LABORATORI  
PASTICCERIA

MERCATI  
SPECIALI

BAR

BIRRA

VINO

EUROLINE

## 8/1 FOOD SIMPATY

150

Forno di cottura statico/grill / Static/grill cooking oven / Four de cuisson statique/grill  
Kochen Backofen statisch/Grill / Horno de cocina estática/grill



GEMINI

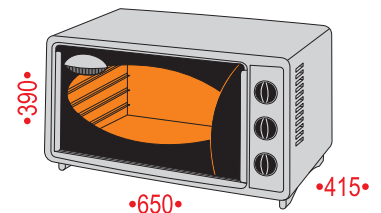

Luce interna  
Internal light  
Plafonnier  
Innenlicht  
Luz interior

Timer con suoneria  
Timer with alarm  
Timer avec alerte  
Timer mit Alarm  
Temporizador con alarma

Posizioni regolabili per i vassoi  
Adjustable tray position  
Positions réglables pour plateaux  
Verstellbare Positionen für Schalen  
Niveles regulables para bandeja

Costruzione in lamiera verniciata grigio  
Construction in grey painted plate  
Construction en tôle verni en gris.  
Gehäuse aus lackiertem grauen Blech  
Construcción en chapa barnizada gris

Dotazione interna:  
N° 1 griglia mm. 440x325  
N° 2 teglie mm. 435x325  
Internal equipment:  
No. 1 440x325 mm. grille  
No. 2 435x325 mm. baking pans  
Dotation intérieure:  
N° 1 Grille mm. 440x325  
N° 2 plats à rôtir mm. 435x325  
Inenausstattung:  
N° 1 Roste mm. 440x325  
N° 2 Backform mm. 435x325  
Equipamiento interior:  
N° 1 parrilla mm. 440x325  
N° 2 bandeja mm. 435x325

Forni a microonde / Microwave ovens / Fours à micro-ondes / Mikrowelle-öfen / Hornos a microondas

FMO 1007 DIGIT

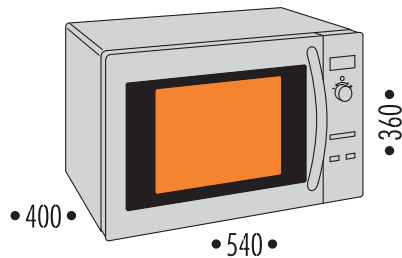

Questo modello può essere appoggiato o incastrato  
This model can be rested or built in  
Ce modèle peut être posé ou encastré  
Diese Model kann man aufstuetzen oder einspannen /  
Este modelo puede ser apoyado o encajonado

Piano girevole con tasto d'arresto  
Rotating plate with stop key  
Plateau tournant avec bouton d'arret  
Drehbare Platte mit Stoptaste  
Plano giratorio con tacto de arresto



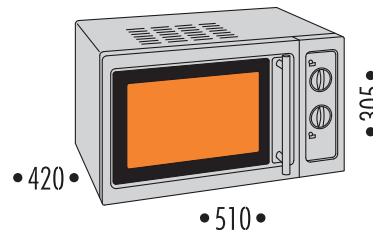



FMO 900 MANUAL



Piano girevole  
Rotating plate  
Plateau tournant  
Drehbare Platte  
Plano giratorio

Costruzione in acciaio inox  
Construction in stainless steel  
Construction en acier inox  
Gehäuse aus rostfreiem Stahl  
Construcción en acero inox



Modello Model Modèle Modell Modelo	Potenza Power Puissance Gesamtleistung Potencia	Tensione Tension Tension Spannung Tension	Capacità Capacity Capacité Gerräumvolumen Capacidad	Livelli di potenza Power levels Niveaux de puissance Leistungspegel Niveles de potencia	Dimensioni interne Cavity dimensions Dim. intérieures Gerräumabmessungen Dim. interiores	Peso netto Net weight Poids net Nettogewicht Peso neto
 <b>GEMINI</b>	 Watt 650+800	 230v/1/50Hz	 Lt. 39	da 80 a 320 °C	 mm. 420x340x240	 Kg 13
<b>FMO 900 MANUAL</b>	Watt 900	230v/1/50Hz	Lt. 23	5	mm. 330x300x205	Kg 16
<b>FMO 1007 DIGIT</b>	Watt 1000	220-240v/1/50Hz	Lt. 32	7	mm. 350x320x255	Kg 20

Forni a microonde / Microwave ovens / Fours à micro-ondes / Mikrowelle-öfen / Hornos a microondas



**FMO 1000 DIGIT BAR**

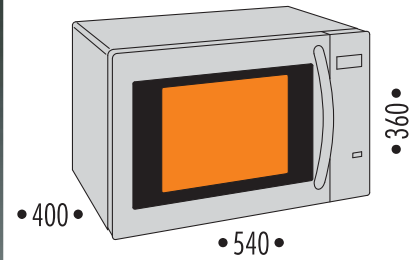

Piano girevole / Rotating plate  
Plateau tournant / Drehbare Platte  
Plano giratorio

Questo modello può essere appoggiato o incastrato  
This model can be rested or built in  
Ce modèle peut être posé ou encastré  
Diese Model kann man aufstuetzen oder einspannen / Esto modelo puede ser apoyado o encajonado

Dimensioni interne / Cavity dimensions / Dim. intérieures  
Geräumabmessungen / Dim. interiores  
mm. 350x320x255



**FMO 1015 DIGIT**

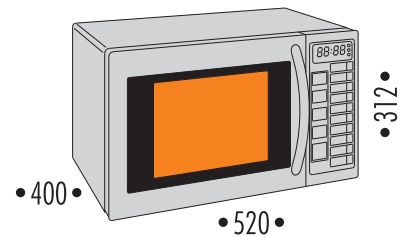

Costruzione in acciaio inox  
Construction in stainless steel  
Construction en acier inox  
Gehäuse aus rostfreiem Stahl  
Construcción en acero inox

Forno digitale / Digital oven /  
Four digital / Digitaler Ofen / Horno digital

10 tasti memoria / 10 storage keys  
/ 10 touches de mémoire / 10  
Speichertasten / 10 teclas de memoria

Tasto x2 porzioni / Keys x2 portions  
/ Touche pour 2 portions / Taste für  
2 Portionen / Tecla por 2 porciones

Dimensioni interne  
Cavity dimensions  
Dim. intérieures  
Geräumabmessungen  
Dim. interiores  
mm. 210x335x364

Piatto quadrato in ceramica  
Ceramic squared plate  
Plat carré en ceramique  
Quadrat Teller aus Tonware  
Plato cuadrado en cerámica

Modello  
Model  
Modèle  
Modell  
Modelo

Potenza resa  
Output power  
Puissance rendue  
Ausgang Leistung  
Potencia desarrolada

Potenza assorbita  
Power consumption  
Puissance absorbée  
Leistung aufnahme  
Potencia absorbida

Tensione  
Tension  
Tension  
Spannung  
Tension

Livelli di potenza  
Power levels  
Niveaux de puissance  
Leistungspegel  
Niveles de potencia

Capacità  
Capacity  
Capacité  
Geräumvolume  
Capacidad

Timer  
Timer  
Minuterie  
Schaltuhr  
Temporizador

Peso netto  
Net weight  
Poids net  
Nettogewicht  
Peso neto



**FMO 1000 DIGIT BAR**



Watt 1000



–



220-240v/1/50Hz



Lt. 32



–



Kg 20

**FMO 1015 DIGIT**

Watt 1000

Watt 1500

230v/1/50Hz

Lt. 32

Min. 90

Kg 15,6

EUROLINE  
VINO  
BIRRA  
BAR  
MERCATI SPECIALI  
LABORATORI PASTICCERIA  
RISTORAZIONE  
FAST FOOD  
PIZZERIA  
CUCINA  
ESPOSIZIONE  
SUPERMERCATI  
HYPERMARKET

## 8/1 FOOD SIMPATY





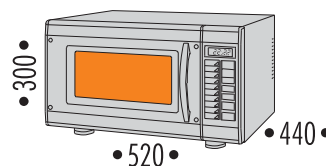



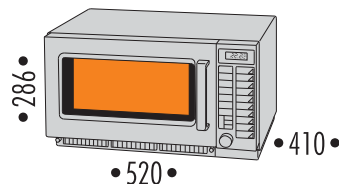



152

Forni a microonde / Microwave ovens / Fours à micro-ondes / Mikrowelle-öfen / Hornos a microondas

VEGA EM-S 1000  
1/2 GNForno digitale / Digital oven /  
Four digital / Digitaler Ofen / Horno  
digital10 tasti memoria / 10 storage keys  
/ 10 touches de mémoire / 10  
Speichertasten / 10 teclas de memoria10 livelli di potenza / 10 power  
levels / 10 niveaux de puissance /  
10 Leistungsstufen / 10 niveles de  
potenciaTasti x2 - x3 porzioni / Keys x2 -  
x3 portions / Touches pour 2 - 3  
portions / Tasten für 2-3 Portionen  
Teclas por 2-3 porcionesPiatto fisso in vetro ceramica  
Fixed plate made of ceramic glass  
Plateau fixe en vitrocéramique  
Fester Teller aus Glaskeramik  
Plato fijo de vidrio cerámicoInterno ed esterno in acciaio inox  
Inside and outside made of stainless  
steel / Intérieur et extérieur en acier  
inoxydable / Innen- und Aussenteile  
aus rostfreiem Stahl / Interior y exterior  
en acero inoxidable1/2 Gastronorm / 1/2 Gastronorm  
1/2 Gastronorm / 1/2 Gastronorm  
1/2 GastronormTimer da 10 min. al 100% e 30 min.  
al 10% di potenza10 minute timer with 100% power  
and 30 min. timer with 10% power  
/ Minuteur de 10 minutes à 100%  
de puissance et de 30 minutes à 10%  
de puissance / Stoppuhr 10 Min. bei  
100% und 30 Min. bei 10% Leistung  
/ Temporizador de 10 minutos con  
100% de potencia y de 30 minutos  
con 10% de potenciaFrequenza microonde  
Frequency  
Fréquence  
Frequenz  
Frecuencia microondas  
Mhz 2450Dimensioni interne  
Cavity dimensions  
Dim. intérieures  
Gerraumabmessungen  
Dim. interiores  
mm. 340x340x180

## VEGA EM-C 1100 D

Forno dotato di 10 livelli di potenza,  
con display digitale e timer manuale.  
Tasti moltiplicatori (x2-x3) per  
riscaldare due o tre piatti  
simultaneamente. Sportello con  
supporto rinforzato che accompagna  
lo sportello e ne mantiene una  
posizione stabile su tutta l'apertura.  
Struttura interna ed esterna in  
acciaio inoxOven with 10 power levels, digital  
display and manual timer. Multiplier  
keys (x2-x3) to heat two or three  
dishes at the same time. Door with  
reinforced support for keeping it steady  
when open. Internal and external  
structures in stainless steel /  
Four équipé de 10 niveaux de  
puissance, avec écran digital et  
minuteur manuel. Touches  
multiplicatrices (x2-x3) pour réchauffer  
simultanément deux ou trois plats.  
Porte avec support renforcé qui  
accompagne le mouvement de la porte  
et permet une position stable de celle-  
ci sur toute l'ouverture. Structure  
interne et externe en acier inox /  
Ofen mit 10 Leistungsstufen, mit  
digitalem Display und manuellemTimer. Vervielfacher-Tasten (x2-x3)  
zum gleichzeitigen Wärmen von 2  
oder 3 Gerichten. Klappe mit verstärkter  
Halterung, die die Klappe begleitet und  
sie in jeder Position der Öffnung stabil  
hält. Innen- und Ausenstruktur aus  
rostfreiem Stahl / Horno dotado con  
diez niveles de potencia, display digital  
y timer manual. Teclas multiplicadoras  
(x2 y x3) para calentar dos o tres  
platos al mismo tiempo. Puerta con  
soporte reforzado que acompaña a la  
puerta en su movimiento para que  
mantenga una posición estable en todo  
el radio de apertura. Estructura exterior  
e interior de acero inoxFrequenza microonde  
Frequency  
Fréquence  
Frequenz  
Frecuencia microondas  
Mhz 2450Dimensioni interne  
Cavity dimensions  
Dim. intérieures  
Gerraumabmessungen  
Dim. interiores  
mm. 330x330x165

Modello Model Modèle Modell Modelo	Potenza resa Output power Puissance rendue Ausgang Leistung Potencia desarrollada	Potenza assorbita Power consumption Puissance absorbée Leistung aufnahme Potencia absorbida	Tensione Tension Tension Spannung Tension	Livelli di potenza Power levels Niveaux de puissance Leistungspegel Niveles de potencia	Capacità Capacity Capacité Gerraumvolumen Capacidad	Timer Timer Minuterie Schaltuhr Temporizador	Peso netto Net weight Poids net Nettogewicht Peso neto
 <b>VEGA EM-S 1000 1/2 GN</b>	 Watt 1000	 Watt 1496	 230v/1/50Hz	10	 Lt. 20	Min. 10 (100%) - 30 (10%)	 Kg 16,5
 <b>VEGA EM-C 1100 D</b>	 Watt 1200	 Watt 1650	 230v/1/50Hz	10	 Lt. 19	Min. 0 + 30	 Kg 22

## Cottura per induzione / Induction cooking / Cuisson par induction / Induktionskochen / Cocción por inducción

Usare pentole con sottofondo in ferro / Use pots with iron bottom / Utiliser des casseroles avec le fond de fer / Benutzen sie Toepfe mit eisernem Boden / Utilizar ollas con fondo de hierro

## CARATTERISTICHE COSTRUTTIVE - CONSTRUCTION FEATURES - CARACTERISTIQUES DE CONSTRUCTION - BAULICHE EIGENSCHAFTEN - CARACTERÍSTICAS DE CONSTRUCCIÓN

Apparecchi conformi alle norme in vigore. Qualità ed affidabilità collaudati da numerosi anni. Sicurezza rafforzata da: riconoscimento recipiente. Rilevazione presenza recipiente. Spegnimento automatico in caso di surriscaldamento o di ritiro del recipiente. Tutti i prodotti sono dotati di temporizzatore.

Appliances compliant with the regulations in force. Tried and tested quality and reliability for many years. Extra safety guaranteed by pan recognition. Pan detection. Automatic switch off in the event of overheating or pan removal. All products equipped with timer. Possibility to design and create customised products. Possibility to supply integrative kits (kit composed of an inducer, a generator, touch-sensitive controls, a ceramic glass plate and various accessories according to need). Appliances guaranteed by the manufacturer for 1 year (bring-in).

Appareils conformes aux normes en vigueur. Qualité et fiabilité éprouvées depuis de nombreuses années. Sécurité renforcée par: La reconnaissance de récipient. La détection de présence de récipient. La coupure automatique en cas surchauffe ou de retrait de récipient. Tous les produits sont équipés d'une minuterie.

Geräte entsprechen den geltenden Vorschriften. Qualität und Zuverlässigkeit – seit vielen Jahren erprobt. Höhere Sicherheit durch: Erkennen des Behälters. Anzeige Behälter vorhanden. Automatisches Ausschalten bei Überhitzung oder Wegnehmen des Behälters. Alle Produkte sind mit Timer versehen.

Aparatos conformes a las normativas vigentes. Calidad y fiabilidad comprobados durante muchos años. Seguridad reforzada por: Reconocimiento del recipiente. Detecta la presencia del recipiente. Se apaga automáticamente en caso de recalentamiento o en caso de que se retire el recipiente. Todos los productos son dotados de temporizador.

## La tecnologia a induzione / Induction technology / La technologie Induction / Induktions-Technologie / Tecnología de inducción

**Il principio di funzionamento:** il calore viene prodotto da un campo magnetico direttamente all'interno del recipiente. Questo campo viene creato elettronicamente. Non ci sono elementi riscaldanti. La cottura avviene praticamente senza alcuna perdita di calore. E' sufficiente togliere il recipiente per fermare la cottura.

**Operating principle:** heat is produced by a magnetic field directly inside the pan. This field is created electronically. There are no heating elements. Cooking takes place with almost no heat loss. Simply remove the pan from the heat to stop cooking.

**Le principe de fonctionnement:** la chaleur est produite par un champ magnétique directement à l'intérieur du récipient. Ce champ est créé électroniquement. Il n'y a pas d'élément chauffant. La cuisson s'effectue sans pratiquement aucune perte de chaleur. Le retrait du récipient suffit à stopper la cuisson.

**Betriebsprinzip:** Die Wärme wird direkt von einem Magnetfeld im Behälter erzeugt. Dieses Feld wird elektronisch geschaffen. Es sind keine Heizelemente vorhanden. Das Kochen erfolgt praktisch ohne jeglichen Wärmeverlust. Einfach Behälter von der Kochstelle nehmen, um Kochvorgang zu beenden.

**Principio de funcionamiento:** El calor se produce por la creación de un campo magnético directamente en el interior del recipiente. Dicho campo magnético se produce electrónicamente. No existen elementos de recalentamiento. La cocción tiene lugar sin producir prácticamente ninguna pérdida de calor. Es suficiente quitar el recipiente para detener la cocción.

**Più flessibile del più piccolo dei bruciatori a gas** / The most flexible of the smaller gas burners / Le plus flexible des plus petits bruleur à gaz / Das flexibelste von den kleinsten Gas Brenner / El mas flexible de los quemadores de gas mas pequenos

**Più rapido del più potente dei fornelli elettrici** / The faster of the most powerful electrical cooking stoves / Le plus vite des plus puissants fourneaux électriques / Schneller als das staerkste von den Elektrischen Herden / El mas rapido del mas potente hornillo eléctrico

**La superficie non brucia le fuoriuscite, quindi il piano di lavoro si pulisce facilmente** / The surface does not burn the discharges so the top can be easily cleaned / La surface ne brûle pas les écoulements donc le plan peut être facilement nettoyé / Die Oberfläche verbrennt das Ausfließen nicht und die Arbeitsfläche kann man sehr leicht putzen / La superficie no quema los escapes así el plano de trabajo se puede limpiar facilmente

**Il più flessibile e il più preciso tra i piani di cottura** / The most flexible and precise cooking plate / La plus flexible et précise plaque de cuisson / Das flexibelste und genauste von den Kochplatten / La placa de coccion mas exacta y flexible

**9 o 12 regolazioni, da 50 a 3600 Watt.** / 9 or 12 adjustments from 50 to 3600 watt / 9 ou 12 réglages de 50 à 3600 Watt / 9 oder 12 Regelungen, von 50 bis 3600 Watt. / 9 o 12 regulaciones de 50 a 3600 watt

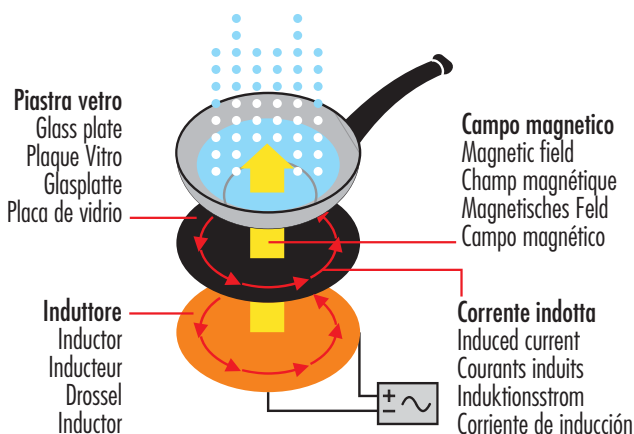

## IL PIÙ ECONOMICO / THE CHEAPER ONE / LE PLUS ÉCONOMIQUE / DER BILLIGSTE / MAS ECONOMICO

**Consumo per portare l'acqua da 20°C a 95°C**  
Consumption to take the temp. from 20°C to 95°C  
Conçommation pour porter la temperature de 20 à 95 °C  
Verbrauch das Wasser von 20°C zu 95°C zu bringen  
Consumo para llevar la temperatura de 20 a 95 °C

**Tempo necessario per portare l'acqua da 20°C a 95°C**  
Necessary time to take the water temp. From 20 to 95 °C  
Temps nécessaire pour porter la temperature de l'eau de 20 à 95 °C  
Zeit verbrauch um das Wasser von 20°C zu 95°C zu bringen  
Tiempo necesario para llevar la temperatura de 20 a 95 °C

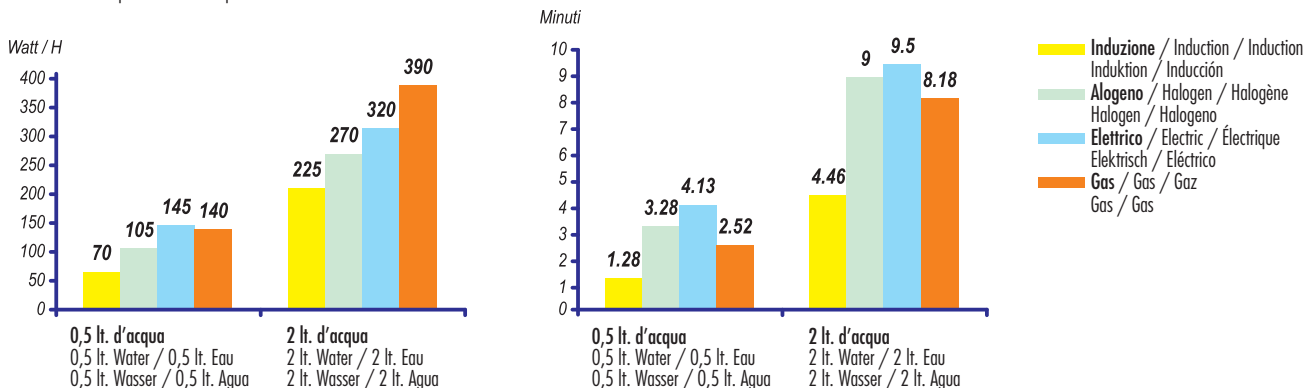

## 8/2 VULCANO

154

Cottura per induzione / Induction cooking / Cuisson par induction / Induktionskochen / Cocción por inducción

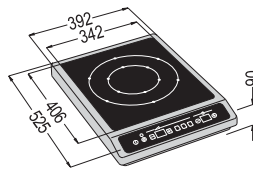
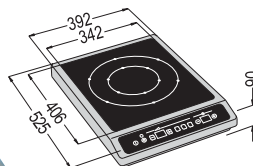
**VULCANO 2.8**  
2800 Watt - 230V/1/50Hz**VULCANO 3.6**  
3600 Watt - 230V/1/50Hz

ATTENZIONE! Per i modelli VULCANO, VULCANO INC, VULCANO 1 e 2 CSD bisogna utilizzare pentolame di diametro NON inferiore a 120 mm ma NON superiore a 280 mm.

ATTENTION! For the models VULCANO, VULCANO INC, VULCANO 1 and 2 CSD you must use stoves NOT less than 120 mm diameter but NOT more than 280 mm diameter.

ATTENTION! Pour les modèles VULCANO, VULCANO INC, VULCANO 1 et 2 CSD on doit utiliser des casseroles avec un diamètre pas inférieur à 120 mm et pas supérieur à 280 mm.

ACHTUNG! Für die Modelle VULCANO, VULCANO INC, VULCANO 1 und 2 CSD muss man Kochtöpfe von einem Durchmesser NICHT kleiner als 120 mm aber NICHT größer als 280 mm verwenden.

ATENCIÓN! Para los modelos VULCANO, VULCANO INC, VULCANO 1 y 2 CSD deben utilizar baterías de cocina con diámetro NON inferior a 120 mm pero NON superior a un diámetro de 280 mm.

DA APPOGGIO  
COUNTER TOP  
POSABLE  
ZUM AUFLEGEN  
DE APOYO

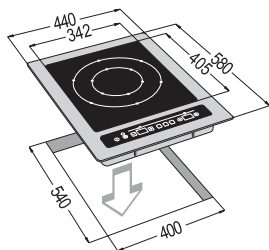
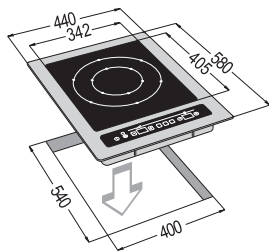
**VULCANO 2.8 INC**  
2800 Watt - 230V/1/50Hz**VULCANO 3.6 INC**  
3600 Watt - 230V/1/50Hz

DA INCASSO  
BUILT IN  
ENCASTRABLE  
ZUM EINBAUEN  
DE ENCASTRE

Modello  
Model  
Modèle  
Modell  
Modelo

Potenza  
Power  
Puissance  
Gesamtleistung  
Potencia

Tensione  
Tension  
Tension  
Spannung  
Tension

Peso netto  
Net weight  
Poids net  
Nettogewicht  
Peso neto

**VULCANO 2.8****VULCANO 3.6****VULCANO 2.8 INC****VULCANO 3.6 INC**

Watt 3000

Watt 3600

Watt 3000

Watt 3600



230v/1/50Hz

230v/1/50Hz

230v/1/50Hz

230v/1/50Hz



Kg 7

Kg 7

Kg 8

Kg 8

Cottura per induzione / Induction cooking / Cuisson par induction / Induktionskochen / Cocción por inducción



**VULCANO 3.6 INC WOK**  
3600 Watt - 230V/1/50Hz

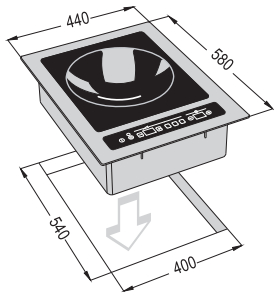

DA INCASSO  
BUILT IN  
ENCASTRABLE  
ZUM EINBAUEN  
DE ENCASTRE

**ATTENZIONE!** Per i modelli VULCANO WOK NON bisogna utilizzare pentolame di diametro superiore a 360 mm.  
**ATTENTION!** For the models VULCANO WOK, you must use stoves NOT more than 360 mm diameter.  
**ATTENTION!** Pour les modèles VULCANO WOK on doit utiliser des casseroles avec un diamètre pas supérieur à 360 mm.

DA APPOGGIO  
COUNTER TOP  
POSABLE  
ZUM AUFLEGEN  
DE APOYO

**VULCANO 3.6 WOK**  
3600 Watt - 230V/1/50Hz

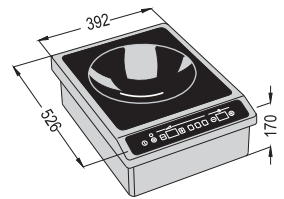

**ACHTUNG!** Für die modelle VULCANO WOK muss man Kochtöpfe von einem Durchmesser NICHT grösser als 360 mm utilisieren.  
**ATENCIÓN!** Para los modelos VULCANO WOK deben utilizar baterías de cocina con diámetro NON superior a 360 mm.

**PLANCHA VULCANO**  
3600 Watt - 230V/1/50Hz

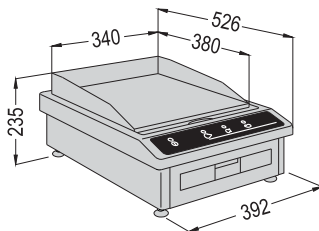

Struttura esterna in acciaio inox che incorpora piano di cottura in materiale composito multistrato  
Exterior frame in stainless steel. It includes cooking top in compound multilayer material  
Structure extérieure en inox qui comprend plan de cuisson en matériel composite multicouche  
Aussere Struktur aus Inox Stahl dass eine Backfläche ingliedert, in beschichtetem Material  
Estructura exterior en acero inoxidable que incluye plano de cocción en material de varias capas

Tre livelli di cottura  
Three coking levels  
Trois niveaux de cuisson  
Drei Niveau's des Kochens  
Tres niveles de cocción

DA APPOGGIO  
COUNTER TOP  
POSABLE  
ZUM AUFLEGEN  
DE APOYO



Modello  
Model  
Modèle  
Modell  
Modelo

Potenza  
Power  
Puissance  
Gesamtleistung  
Potencia

Tensione  
Tension  
Tension  
Spannung  
Tension

Peso netto  
Net weight  
Poids net  
Nettogewicht  
Peso neto



**VULCANO 3.6 WOK**

Watt 3600

230v/1/50Hz

Kg 9

**VULCANO 3.6 INC WOK**

Watt 3600

230v/1/50Hz

Kg 9

**PLANCHA VULCANO**

Watt 3600

230v/1/50Hz

Kg 16

EUROLINE  
VINO  
BIRRA  
BAR  
MERCATI SPECIALI  
LABORATORI PASTICCERIA  
RISTORAZIONE  
FAST FOOD  
PIZZERIA  
CUCINA  
ESPOSIZIONE  
SUPERMERCATI  
HYPERMARKET

## 8/2 VULCANO

156

Cottura per induzione / Induction cooking / Cuisson par induction / Induktionskochen / Cocción por inducción

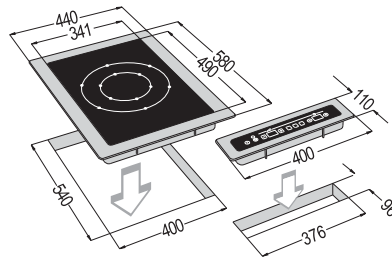
**VULCANO 1 CSD**  
 3600 Watt - 230V/1/50Hz

 DA INCASSO  
 BUILT IN  
 ENCASTRABLE  
 ZUM EINBAUEN  
 DE ENCASTRE

**ATTENZIONE!** Per i modelli VULCANO, VULCANO INC, VULCANO 1 e 2 CSD bisogna utilizzare pentolame di diametro NON inferiore a 120 mm ma NON superiore a 280 mm.

**ATTENTION!** For the models VULCANO, VULCANO INC, VULCANO 1 and 2 CSD you must use stoves NOT less than 120 mm diameter but NOT more than 280 mm diameter.

**ATTENTION!** Pour les modèles VULCANO, VULCANO INC, VULCANO 1 et 2 CSD on doit utiliser des casseroles avec un diamètre pas inférieur à 120 mm et pas supérieur à 280 mm.

**ACHTUNG!** Für die Modelle VULCANO, VULCANO INC, VULCANO 1 und 2 CSD muss man Kochtöpfe von einem Durchmesser NICHT kleiner als 120 mm aber NICHT größer als 280 mm utilisieren.

**ATENCIÓN!** Para los modelos VULCANO, VULCANO INC, VULCANO 1 y 2 CSD deben utilizar baterías de cocina con diámetro NON inferior a 120 mm pero NON superior a un diámetro de 280 mm.

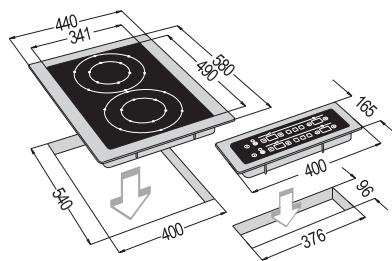
**VULCANO 2 CSD**  
 3200+3200 Watt - 230V/1/50Hz

 DA INCASSO  
 BUILT IN  
 ENCASTRABLE  
 ZUM EINBAUEN  
 DE ENCASTRE

 Modello  
 Model  
 Modèle  
 Modell  
 Modelo

 Potenza  
 Power  
 Puissance  
 Gesamtleistung  
 Potencia

 Tensione  
 Tension  
 Tension  
 Spannung  
 Tension

 Peso netto  
 Net weight  
 Poids net  
 Nettogewicht  
 Peso neto

**VULCANO 1 CSD**

Watt 3600

230v/1/50Hz

Kg 12

**VULCANO 2 CSD**

Watt 3200+3200

230v/1/50Hz

Kg 20

Cottura per induzione / Induction cooking / Cuisson par induction / Induktionskochen / Cocción por inducción

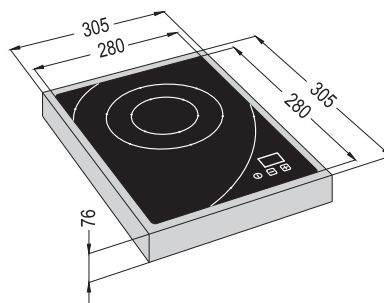
**VULCANO 2.2 MODULO**  
 2200 Watt - 230V/1/50Hz

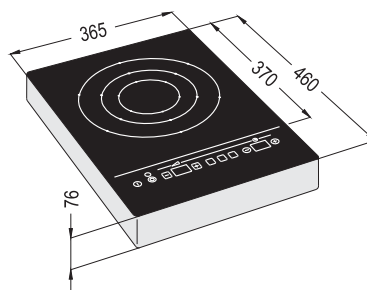
 DA APPOGGIO  
 COUNTER TOP  
 POSABLE  
 ZUM AUFLEGEN  
 DE APOYO

**VULCANO 2.8 MODULO**  
 2800 Watt - 230V/1/50Hz

 DA APPOGGIO  
 COUNTER TOP  
 POSABLE  
 ZUM AUFLEGEN  
 DE APOYO

**ATTENZIONE!** Per i modelli VULCANO, VULCANO INC, VULCANO 1 e 2 CSD bisogna utilizzare pentolame di diametro NON inferiore a 120 mm ma NON superiore a 280 mm.

**ATTENTION!** For the models VULCANO, VULCANO INC, VULCANO 1 and 2 CSD you must use stoves NOT less than 120 mm diameter but NOT more than 280 mm diameter.

**ATTENTION!** Pour les modèles VULCANO, VULCANO INC, VULCANO 1 et 2 CSD on doit utiliser des casseroles avec un diamètre pas inférieur à 120 mm et pas supérieur à 280 mm.

**ACHTUNG!** Für die modelle VULCANO, VULCANO INC, VULCANO 1 und 2 CSD muss man Kochtöpfe von einem Durchmesser NICHT Kleiner als 120 mm aber NICHT grösser als 280 mm utlisieren.

**ATENCIÓN!** Para los modelos VULCANO, VULCANO INC, VULCANO 1 y 2 CSD deben utilizar baterías de cocina con diámetro NON inferior a 120 mm pero NON superior a un diámetro de 280 mm.

 Modello  
 Model  
 Modèle  
 Modell  
 Modelo

 Potenza  
 Power  
 Puissance  
 Gesamtleistung  
 Potencia

 Tensione  
 Tension  
 Tension  
 Spannung  
 Tension

 Peso netto  
 Net weight  
 Poids net  
 Nettogewicht  
 Peso neto
**VULCANO 2.2 MODULO****VULCANO 2.8 MODULO**

Watt 2200

Watt 2800



230v/1/50Hz

230v/1/50Hz



Kg 6

Kg 9

## 8/3 SUN SIMPATY

158

Forni per bar, Fast Food etc. / Ovens for coffee bars, Fast foods etc. Fours pour cafés, Fast Food etc.  
/ Öfen für Kaffee-Bar, Fast Food etc. / Hornos para cafeterías, Fast Food, etc.



SIRIO

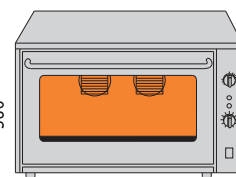

• 530 •

• 680 •

• 825 •

**Esterno e interno in acciaio inox**  
Inside outside made of stainless steel  
Extérieur et intérieur en acier inox  
Ausseres und Inneres aus rostfreiem Stahl / Exterior e interior en acero inoxidable

**Porta smontabile**  
Detachable door / Porte démontable  
Abnehmbare Tür / Puerta desmontable

**Piedini regolabili**  
Adjustable feet / Pieds réglables  
Verstellbare Füße / Pies ajustables

**Vetro porta temperato doppio**  
Double toughened glass panel for doors  
/ Verre trempé double pour porte /  
Vorgespanntes Verbundglass für Türe  
/ Vidrio puerta templado doble

**Comando manuale uscita fumi**  
Smoke outlet manual control /  
Commande manuelle pour sortie de  
fumée / Handsteuerung für  
Rauchaustritt / Mando manual para  
salida de humos

**Microinterruttore porta**  
Door microswitch / Microinterrupteur  
pour porte / Mikroschalter Türe /  
Microinterruptor puerta

**Comandi analogici**  
Analog control / Commande  
analogique / Analogsteuerung /  
Mandos analógicos

**Umidificatore**  
Humidifier / Humidificateur  
Anfeuchter / Humidificador

**Luce interna**  
Internal light / Lumière intérieure  
Innenlicht / Luz interior  
X2

**Motori per ventilatori**  
Motors for fans / Moteurs pour  
ventilateurs / Lüftermotoren / Motores  
para ventiladores  
N° 2

**N° livelli di carico griglie/teglie**  
No. loading levels for grates/baking pans  
N. niveau de charge grilles/plats à rôtir  
N. Ladeniveau für Gitter/Backformen  
N° nivel de carga parrillas/bandejas  
N° 4

**Funzionamento**  
Operation  
Fonctionnement  
Betrieb  
Funcionamiento

**Tipo ventole**  
Fan type  
ype de ventilateur  
Lüfterrad-Typ  
Tipo de ventiladores

**Elettrico-ventilato**

Electric-ventilated / Electrique-ventilé /  
Elektrisch-gelüftet / Eléctrico-ventilado

**A pale radiali**

Radial vane (fans) / A pales radiales  
Mit radialen Flügeln / De palas radiales



**Ventilazione interna con due ventole controrotanti in senso alternato**  
Internal ventilation with 2 counter-rotating fans in alternate directions  
Innenlüftung mit 2 abwechselnd gegenläufigen Lüfterrädern  
Ventilation intérieure avec 2 ventilateurs contrarotatifs à sens alterné  
Ventilación interior con 2 ventiladores contrarotantes en sentido alternado

Modello Model Modèle Modell Modelo	Potenza Power Puissance Gesamtleistung Potencia	Tensione Tension Tension Spannung Tension	Temperatura Temperature Temperature Temperatur Temperatura	Regolazione termostato Thermostat adjustment Réglage du thermostat Thermostat-Regelung Reglaje del termostato	Timer di regolazione Adjustment timer Minuteur de réglage Timer für die Regelung imer de regulación	Peso netto Net weight Poids net Nettogewicht Peso neto
<b>SIRIO</b>	Kw 3,5 / 4,5 / 5,45 (Regolabili / Adjustable / Réglable / Verstellbar / Regulable)	230v/1/50Hz 400v/3/50Hz	°C 250 max	°C +50/+250	0/60'	Kg 51

*Forni per bar, Fast Food etc. / Ovens for coffee bars, Fast foods etc. Fours pour cafés, Fast Food etc. / Öfen für Kaffee-Bar, Fast Food etc. / Hornos para cafeterías, Fast Food, etc.*



### ORION

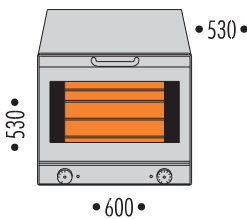

**Funzionamento**  
Operation  
Fonctionnement  
Betrieb  
Funcionamiento

**Tipo ventole**  
Fan type  
ype de ventilateur  
Lüfterrad-Typ  
Tipo de ventiladores

**Elettrico-ventilato**  
Electric-ventilated / Electrique-ventilé /  
Elektrisch-gelüftet / Eléctrico-ventilado

**A pale inclinate**  
Curved blades (FAN) / A pelles inclinées  
Mit schiefe schaufeln / A paletas inclinadas

**Forno termovenilato con ventilazione a pale inclinate. La combinazione ventola/resistenza consente la cottura di cibi diversi.**  
Air-heated oven with angled fan blades. / Different foods can be cooked using the fan/resistor combination. / Four thermo-ventilé avec ventilation à pales inclinées. La combinaison ventilateur/resistance permet la cuisson de différents aliments / Wärmegelüfter Ofen mit Lüftung mittels geneigter Flügel. Die Kombination Lüfterrad/Widerstand ermöglicht das Kochen verschiedener Speisen. / Horno termovenilado mediante ventilador de palas inclinadas. La combinación ventilador-resistencia consiente la cocción de alimentos distintos

**Dotazione interna:**  
N° 4 teglie piane in alluminio mm. 430x320  
**Internal equipment:**  
No. 4 430x320mm aluminium flat baking pans  
**Dotation intérieure:**  
N. 4 plats à rôtis plans en aluminium mm. 430x320  
**Innenausstattung:**  
N. 4 flache Backformen aus Aluminium mm. 430x320  
**Equipamiento interior:**  
N° 4 bandejas planas en aluminio mm. 430x320

**Involucro esterno:**  
**Lamiera preverniciata**  
External structure: Pre-painted sheet metal / Structure externe: Tôle pré-vernée / Außenstruktur: Vorlackiertes Blech / Estructura exterior: Chapa prebarnizada

**Involucro interno:**  
**Lamiera smaltata**  
Internal structure: Enamelled sheet metal / Structure interne: Tôle émaillée / Innenstruktur: Emailiertes Blech / Estructura interior: Chapa esmaltada

**Comando manuale uscita fumi**  
Smoke outlet manual control / Commande manuelle pour sortie de fumée / Handsteuerung für Rauchaustritt / Mando manual para salida de humos

**Micrinterruttore porta**  
Door microswitch / Microinterrupteur pour porte / Mikroschalter Türe / Microinterruptor puerta

**Porta smontabile**  
Detachable door / Porte démontable / Abnehmbare Tür / Puerta desmontable





**Piedini regolabili**  
Adjustable Teet / Pieds réglables / Verstellbare Füße / Pies ajustables

**Vetro porta temperato doppio**  
Double toughened glass panel for doors / Verre trempé double pour porte / Vorgespanntes Verbundglass für Türe / Vidrio puerta templado doble

**Comandi analogici**  
Analog control / Commande analogique / Analogsteuerung / Mandos analógicos

**Luce interna**  
Internal light / Lumière intérieure / Innenlicht / Luz interior  
X1

**Motori per ventilatori**  
Motors for fans / Moteurs pour ventilateurs / Lüftermotoren / Motores para ventiladores  
N° 1

Modello Model Modèle Modell Modelo	Potenza Power Puissance Gesamtleistung Potencia	Tensione Tension Tension Spannung Tension	Temperatura Temperature Temperature Temperatur Temperatura	Regolazione termostato Thermostat adjustment Réglage du thermostat Thermostat-Regelung Reglaje del termóstato	Timer di regolazione Adjustment timer Minuteur de réglage Timer für die Regelung imer de regulación	N° livelli di carico griglie/teglie No. loading levels for grates/baking pans N. niveau de charge grilles/plats à rôtir N. Ladeniveau für Gitter/Backformen N° nivel de carga parrillas/bandejas	Peso netto Net weight Poids net Nettogewicht Peso neto
 <b>ORION</b>	 Kw 2,7	 230v/1/50Hz	 °C 250 max	°C +50/+250	0/60'	N° 4	 Kg 36

EUROLINE  
VINO  
BIRRA  
BAR  
MERCATI SPECIALI  
LABORATORI PASTICCERIA  
RISTORAZIONE  
FAST FOOD  
PIZZERIA  
CUCINA  
ESPOSIZIONE  
SUPERMERCATI  
HYPERMARKET

## 8/3 SUN SIMPATY

160

*Forni per bar, Fast Food etc. / Ovens for coffee bars, Fast foods etc. Fours pour cafés, Fast Food etc. / Öfen für Kaffee-Bar, Fast Food etc. / Hornos para cafeterías, Fast Food, etc.*



NAXOS

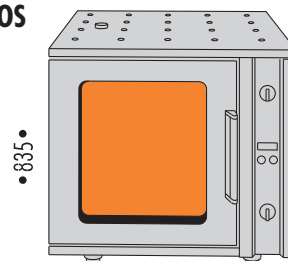

• 832 •

• 835 •

• 871 •

**Forno inox termoventilato ed umidificato**

Stainless steel moisturized and thermoventilated oven / Four thermoventilé et humidifié en acier inox / Angefeuchteter Thermogeluefteter Ofen in Inox / Horno termoventilado y humidificado en acero inox

**E' dotato di sistema di umidificazione che nebulizza acqua immessa mediante allacciamento alla rete idrica. L'acqua a contatto con la ventola produce vapore. La combinazione ventola/resistenza circolare (incorporata nella schiena del forno) consente la cottura di cibi diversi su piu' piani. Struttura interna ed esterna interamente in acciaio inox**

• It has a humidification system which nebulizes water introduced through the connection to the water network. The water coming into contact with the fan produces steam. The combination fan/circular resistor (incorporated in the rear of the oven), means that different foods may be cooked on several shelves. The entire external and internal structure is in stainless steel /

• Il est doté d'un système d'humidification qui nébulise de l'eau introduite par un branchement au réseau hydrique. L'eau qui entre en contact avec le ventilateur produit de la vapeur. La combinaison ventilateur / résistance circulaire (incorporée à l'arrière du four) permet la cuisson de différents aliments sur plusieurs plans. Structure interne et externe entièrement en acier inox /

• Verfügt über ein Befeuchtungssystem, welches das über den Wassernetzanschluss eingegebene Wasser zersträubt. Das mit dem Windrad in Kontakt gekommene Wasser produziert Dampf. Die Kombination Lüfterrad/Kreiswiderstand (im hinteren Teil des Ofens eingebaut) ermöglicht das Kochen von verschiedenen Speisen auf mehreren Ebenen. Innen- und Außenstruktur komplett aus rostfreiem Stahl / Está provisto de un sistema de humidificación que nebuliza agua proveniente de una conexión a la red. • El agua en contacto con el rotor produce vapor. La combinación ventilador-resistencia circular (incorporada en el fondo del horno), consente la cocción de alimentos distintos en diferentes bandejas. Estructura exterior e interior completamente de acero inox

**Esterno e interno in acciaio inox**  
Inside outside made of stainless steel  
Extérieur et intérieur en acier inox  
Ausseres und Inneres aus rostfreiem Stahl / Exterior e interior en acero inoxidable

**Porta smontabile**  
Detachable door / Porte démontable  
Abnehmbare Tür / Puerta desmontable

**Piedini regolabili**  
Adjustable feet / Pieds réglables  
Verstellbare Füße / Pies ajustables

**Vetro porta temperato doppio**  
Double toughened glass panel for doors  
/ Verre trempé double pour porte /  
Vorgespanntes Verbundglass für Türe /  
Vidrio puerta templado doble

**Comando manuale uscita fumi**  
Smoke outlet manual control /  
Commande manuelle pour sortie de fumée /  
Handsteuerung für Rauchaustritt /  
Mando manual para salida de humos

**Microinterruttore porta**  
Door microswitch / Microinterrupteur  
pour porte / Mikroschalter Türe /  
Microinterruptor puerta

**Comandi elettronici**  
Electronic control panel / Panneau de commandes électronique /  
Elektronische Steuerung / Mandos electrónicos

**Umidificatore**  
Humidifier / Humidificateur  
Anfeuchter / Humidificador

**Luce interna**  
Internal light / Lumière intérieure  
Innenlicht / Luz interior  
X2

**Motori per ventilatori**  
Motors for fans / Moteurs pour ventilateurs / Lüftermotoren / Motores para ventiladores  
N° 2

**N° livelli di carico griglie/teglie**  
No. loading levels for grates/baking pans  
N. niveau de charge grilles/plats à rôtir  
N. Ladeniveau für Gitter/Backformen  
N° nivel de carga parrillas/bandejas  
mm 600x400 - GN 1/1  
N° 6

**Funzionamento**  
Operation  
Fonctionnement  
Betrieb  
Funcionamiento

**Tipo ventole**  
Fan type  
ype de ventilateur  
Lüfterrad-Typ  
Tipo de ventiladores

**Elettrico-ventilato**

Electric-ventilated / Electrique-ventilé /  
Elektrisch-gelüftet / Eléctrico-ventilado

**A pale radiali**

Radial vane (fans) / A pales radiales  
Mit radialen Flügeln / De palas radiales



**Ventilazione interna con due ventole controrotanti in senso alternato**  
Internal ventilation with 2 counter-rotating fans in alternate directions  
Innenlüftung mit 2 abwechselnd gegenläufigen Lüfterrädern  
Ventilation intérieure avec 2 ventilateurs contrarotatifs à sens alterné  
Ventilación interior con 2 ventiladores contrarotantes en sentido alternado

**Modello**  
Model  
Modèle  
Modell  
Modelo

**Potenza**  
Power  
Puissance  
Gesamtleistung  
Potencia

**Tensione**  
Tension  
Tension  
Spannung  
Tension

**Temperatura**  
Temperature  
Temperature  
Temperatur  
Temperatura

**Regolazione termostato**  
Thermostat adjustment  
Réglage du thermostat  
Thermostat-Regelung  
Reglaje del termostato

**Timer di regolazione**  
Adjustment timer  
Minuteur de réglage  
Timer für die Regelung  
imer de regulación

**Peso netto**  
Net weight  
Poids net  
Nettogewicht  
Peso neto

**NAXOS**

Kw 3,5 / 5,5 / 8,3

(Regolabili / Adjustable / Réglable / Verstellbar / Regulable)

230v/1/50Hz  
400v/3/50Hz

°C 300 max



°C +50/+300



0/99' + ∞



Kg 92

*Forni per bar, Fast Food etc. / Ovens for coffee bars, Fast foods etc. Fours pour cafés, Fast Food etc.  
/ Öfen für Kaffee-Bar, Fast Food etc. / Hornos para cafeterías, Fast Food, etc.*

## LIEVITA S



**Lievitatori riscaldati umidificati inox**  
Humidified stainless steel heated rising cabinets

Machines à lever chauffées et humidifiées en inox

Geheizte befeuchtete Hefemaschine Inox

Armarios de fermentacion enchufados humidificados inox

## LIEVITA N

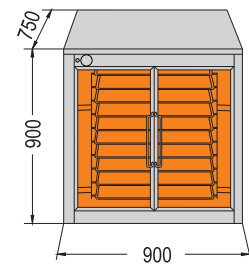

**2 termostati regolabili**  
2 adjustable thermostats  
2 thermostat réglables  
2 verstellbare Thermostate  
2 termostatos regulables

**Capienza teglie**  
Baking-pan capacity  
Capacité plateaux  
Kapazität Bleche  
Capacidad bandejas  
N° 10 Euronorm 600x400 mm

**Struttura in acciaio inox 10/10**  
10/10 stainless steel frame  
Structure en inox 10/10  
Struktur aus Inox 10/10  
Estructura en acero inox 10/10

**Chiusura con doppia calamita**  
Fastening with double magnet  
Fermeture avec double aimant  
Abschluß mit doppeltem Magnet  
Cierre con doble imán

## LIEVITA S

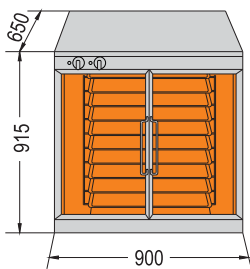













**Termostato regolabile in tre posizioni:**  
Three positions adjustable thermostat  
Thermostat réglable en trois niveaux  
Verstellbares Thermostat in 3 Positionen  
Termostato regulable en tres posiciones  
Min (25 - 35 °C)  
Med (35 - 65 °C)  
Max (65 - 85 °C)

**Umidificatore regolabile in tre posizioni:**  
three positions adjustable humidifier  
Humidificateur réglable sur trois niveaux  
Anfeuchter verstellbar in 3 Positionen  
Humidificador regulable en tres posiciones  
Min (25 - 35 °C)  
Med (35 - 65 °C)  
Max (65 - 85 °C)

**Struttura in acciaio inox 18/10**  
18/10 stainless steel frame  
Structure en inox 18/10  
Struktur aus Inox 18/10  
Estructura en acero inox 18/10

**Capienza teglie**  
Baking-pan capacity  
Capacité plateaux  
Kapazität Bleche  
Capacidad bandejas  
N° 10 Euronorm 600x400 mm

**Chiusura con doppia calamita**  
Fastening with double magnet  
Fermeture avec double aimant  
Abschluß mit doppeltem Magnet  
Cierre con doble imán

Modello Model Modèle Modell Modelo	Potenza Power Puissance Gesamtleistung Potencia	Tensione Tension Tension Spannung Tension	Temperatura Temperature Temperature Temperatur Temperatura	Dimensioni Dimensions Dimensions Abmessungen Dimensiones	Peso netto Net weight Poids net Nettogewicht Peso neto
 <b>LIEVITA-N</b>	 Watt 950	 230v/1/50Hz	 °C +25/+85	 mm. 900x750x900	 Kg 55
 <b>LIEVITA-S</b>	 Watt 950	 230v/1/50Hz	 °C +25/+85	 mm. 900x650x915	 Kg 50

## 8/4 FOOD SPRINTER

162

*Fornetti a gas "snack" / Gas cooking stoves "snack" / Réchauds à gaz "snack" / Gaskochplatten "snack" / Hornillos de gas "snack"*

**Modular**

**Struttura in acciaio inox**  
Stainless steel structure  
Structure en acier inox  
Struktur aus rostfreiem Stahl  
Estructura de acero inox

**Accensione elettrica**  
Electric ignition  
Allumage électrique  
Elektrische Anzündung  
Encendido eléctrico

**Piastra in ghisa**  
Galvanized pig-iron  
Claque en fonte brute  
Platte aus Roheisen  
Plancia en hierro en lingotes

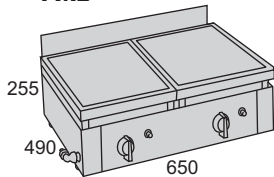
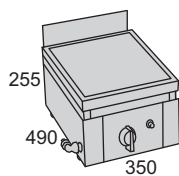
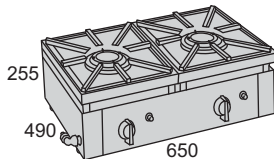
**PM2****PM1****Modular****PF2**

**Struttura in acciaio inox**  
Stainless steel structure  
Structure en acier inox  
Struktur aus rostfreiem Stahl  
Estructura de acero inox

**Accensione elettrica**  
Electric ignition  
Allumage électrique  
Elektrische Anzündung  
Encendido eléctrico

Modello Model Modèle Modell Modelo	Potenza Power Puissance Gesamtleistung Potencia	Kcal/h Kcal/h Kcal/h Kcal/h	LxP Piastre LxD Hot plate LxL Plaques chauffantes LxB Warmhalte platten LxP Planchas calientes	Brucciatore Burner Bruleur Brenner Quemador	Fornello Cooking stove Réchaud Kocher Hornillo	Valvola Valve Soupape Ventil Valvula	Peso netto Net weight Poids net Nettogewicht Peso neto
 <b>PM1</b>	Kw 3,6	3.095	300x400	N° 1	–	N° 1	Kg 14,5
<b>PM2</b>	Kw 7,2	6.191	2x300x400	N° 2	–	N° 2	Kg 30,5
<b>PF2</b>	Kw 7,6	6.534	–	–	N° 2	N° 2	Kg 29,5

*Fornetti a gas "snack" / Gas cooking stoves "snack" / Réchauds à gaz "snack" / Gaskochplatten "snack" / Hornillos de gas "snack"*

**Extra**



**PE 60**

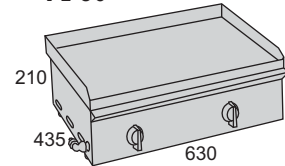

**Struttura in acciaio inox**  
Stainless steel structure  
Structure en acier inox  
Struktur aus rostfreiem Stahl  
Estructura de acero inox

**Piano cottura in ferro**  
Iron cooking surface  
Surface de cuisson en fer  
Kochen Oberfläche aus Eisen  
Superficie de cocina en hierro

**Extra**





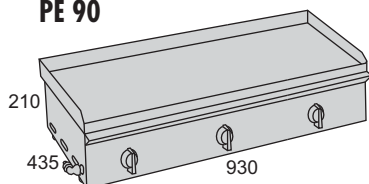

**PE 90**



**Struttura in acciaio inox**  
Stainless steel structure  
Structure en acier inox  
Struktur aus rostfreiem Stahl  
Estructura de acero inox

**Piano cottura in ferro**  
Iron cooking surface  
Surface de cuisson en fer  
Kochen Oberfläche aus Eisen  
Superficie de cocina en hierro

Modello Model Modèle Modell Modelo	Potenza Power Puissance Gesamtleistung Potencia	Kcal/h Kcal/h Kcal/h Kcal/h	LxP Piastre LxD Hot plate LxL Plaques chauffantes LxBWarmhalte platten LxP Planchas calientes	Bruciatore Burner Bruleur Brenner Quemador	Fornello Cooking stove Réchaud Kocher Hornillo	Valvola Valve Soupape Ventil Valvula	Peso netto Net weight Poids net Nettogewicht Peso neto
 <b>PE60</b>	 Kw 7,2	6.191	600x400	N° 2	–	N° 2	Kg 23,5
 <b>PE90</b>	 Kw 10,8	9.286	900x400	N° 3	–	N° 3	Kg 34

## 8/4 FOOD SPRINTER

164

*Fornetti a gas "snack" / Gas cooking stoves "snack" / Réchauds à gaz "snack" / Gaskochplatten "snack" / Hornillos de gas "snack"*

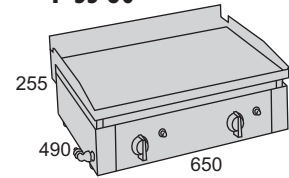
**Super Snack****P SS 60**

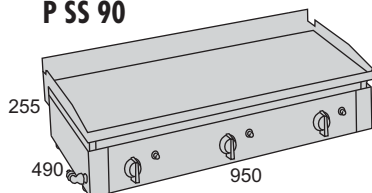

**Struttura in acciaio inox**  
Stainless steel structure  
Structure en acier inox  
Struktur aus rostfreiem Stahl  
Estructura de acero inox

**Piano cottura in ferro**  
Iron cooking surface  
Surface de cuisson en fer  
Kochen Oberfläche aus Eisen  
Superficie de cocina en hierro

**Super Snack****P SS 90**

**Struttura in acciaio inox**  
Stainless steel structure  
Structure en acier inox  
Struktur aus rostfreiem Stahl  
Estructura de acero inox

**Piano cottura in ferro**  
Iron cooking surface  
Surface de cuisson en fer  
Kochen Oberfläche aus Eisen  
Superficie de cocina en hierro

Modello Model Modèle Modell Modelo	Potenza Power Puissance Gesamtleistung Potencia	Kcal/h Kcal/h Kcal/h Kcal/h	LxP Piastre LxD Hot plate LxL Plaques chauffantes LxB Warmhalteplatten LxP Planchas calientes	Bruciatore Burner Bruleur Brenner Quemador	Fornello Cooking stove Réchaud Kocher Hornillo	Valvola Valve Soupape Ventil Valvula	Peso netto Net weight Poids net Nettogewicht Peso neto
 <b>P SS 60</b>	Kw 7,2	6.191	600x400	N° 2	–	N° 2	Kg 35,5
 <b>P SS 90</b>	Kw 10,8	9.286	900x400	N° 2	–	N° 3	Kg 50,5

**GASTRONORM 2/1 VISTA**

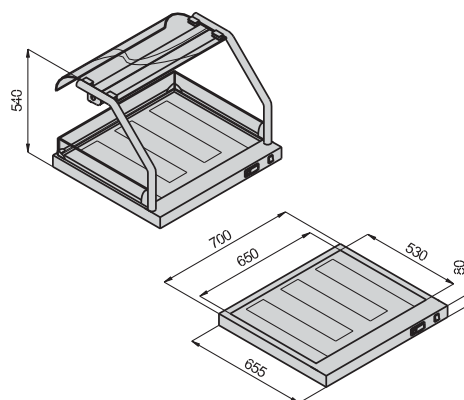

**GASTRONORM 2/1 BASE**



**EURONORM VISTA**

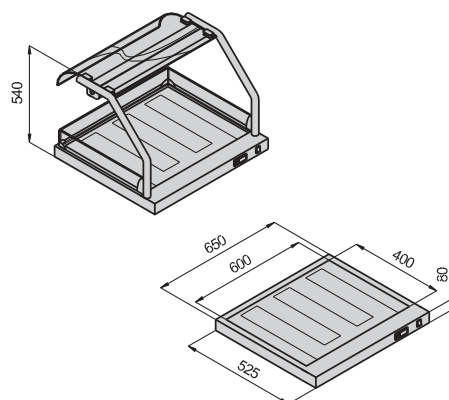

**EURONORM BASE**

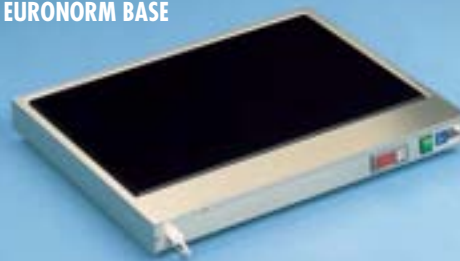

Modello  
Model  
Modèle  
Modell  
Modelo

Potenza  
Power  
Puissance  
Gesamtleistung  
Potencia

Tensione  
Tension  
Tension  
Spannung  
Tension

Temperatura  
Temperature  
Temperature  
Temperatur  
Temperatura

Potenza raggi infrarossi  
Infrared ray power  
Puissance des rayons infrarouges  
Leistung der infraroten Strahlen  
Potencia rayos infrarrojos

Potenza piastre in vetro ceramico  
Glass-ceramic plate power  
Puissance des plaques en céramique de verre  
Leistung der Platten aus Glaskeramik  
Potencia placas en vidrio-cerámica

Peso netto  
Net weight  
Poids net  
Nettogewicht  
Peso neto



**GASTRONORM 2/1 BASE**

Watt 900

230v/1/50Hz

°C +30/+120

-

Watt 600

Kg 15

**GASTRONORM 2/1 VISTA**

Watt 900

230v/1/50Hz

°C +30/+120

Watt 300

Watt 600

Kg 25

**EURONORM BASE**

Watt 700

230v/1/50Hz

°C +30/+120

-

Watt 400

Kg 12

**EURONORM VISTA**

Watt 700

230v/1/50Hz

°C +30/+120

Watt 300

Watt 400

Kg 20

EUROLINE  
VINO  
BIRRA  
BAR  
MERCATI SPECIALI  
LABORATORI PASTICCERIA  
RISTORAZIONE  
FAST FOOD  
PIZZERIA  
CUCINA  
ESPOSIZIONE  
SUPERMERCATI  
HYPERMARKET

## 8/5 HOT PLATE

166



## PIZZA BASE

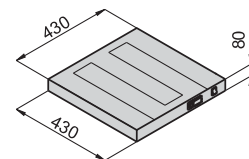

Con le nuove piastre calde in vetroceramico modello HOT PLATE, la gamma dei soprabanco COLD MASTER si amplia e si arricchisce di uno strumento ideale per l'esposizione di alimenti che devono essere mantenuti caldi quali pizzette, croissants, panini, ecc. Le diverse dimensioni (Gastronorm, Euronorm e Pizza) si adattano alle esigenze del ristorante moderno, mentre l'utilizzo di materiali quali il vetro-ceramico e l'acciaio inox permettono un'agevole pulizia rispettando così gli aspetti igienico alimentari. Due le versioni: (1) piastra d'appoggio riscaldata mod. BASE, (2) piastra d'appoggio riscaldata con protezioni laterali e lampada a raggi infrarossi per riscaldamento dall'alto mod. VISTA.

The new ceramic-glass HOT PLATE hot grids widen and enrich COLD MASTER counter products range with an ideal element to exhibit hot foodstuffs such as pizzas, croissants, sandwiches, etc. The different dimensions (Gastronorm, Euronorm and Pizza) meet the needs of modern restaurants and the use of materials such as glass-ceramic and stainless steel allows for an easy cleaning according to hygiene and food requirements. There are two versions: (1) supporting hot plate mod. BASE, (2) supporting hot plate with side protections and infra-red lamp to heat from above mod. VISTA.

Grâce aux nouvelles plaques chaudes en céramique de verre HOT PLATE la gamme des dessus de banc COLD MASTER s'élargit et s'enrichit d'un instrument idéal pour l'exposition d'aliments qui doivent rester chauds, comme, par exemple, les pizzas, les croissants, les sandwich, etc. Les différentes dimensions à votre disposition (Gastronorm, Euronorm et Pizza) s'adaptent aux exigences des restaurants modernes, alors que l'utilisation de matériaux comme la céramique de verre et l'acier inoxydable permettent un nettoyage facile, respectant ainsi la protection hygiénique et sanitaire. Deux versions: (1) plaque d'appui chauffée mod. BASE, (2) plaque d'appui chauffée ayant protections latérales et lampes à rayons infrarouges pour chauffage du haut Mod. VISTA.

Die neuen Kochplatten HOT PLATE aus Glaskeramik erweitern und bereichern die Ladentisch-Produktpalette mit einem idealen Mittel zum Schauen von heißen Speisen wie Pizzas, Croissants, Sandwiches, usw. Die verschiedenen Massen (Gastronorm, Euronorm und Pizza) entsprechen den Ansprüchen der modernen Restaurants und Materialien wie Glaskeramik und Edelstahl erlauben eine einfache Reinigung nach hygienischen und Nahrungsmittelanforderungen. Zwei Ausführungen: (1) geheizte Aufsetzplatte Mod. BASE; (2) geheizte Aufsetzplatte mit seitlichem Schutz und Infrarotstrahler für Infrarot-Strahlungsheizung von oben Mod. VISTA.

Las nuevas planchas calentadas HOT PLATE amplían e enriquecen la serie de productos de barra con un instrumento ideal para mostrar alimentos calientes como pizzas, croissants, bocadillos, etc. Las distintas dimensiones (Gastronorm, Euronorm y Pizza) responden a las exigencias de los modernos restaurantes, mientras el uso de materiales como la vidrio-cerámica y el acero especial permiten limpiar sencillamente según las exigencias higiénicas y alimentarias. Dos versiones: (1) Placa caliente modelo BASE, (2) placa de apoyo caliente con protecciones laterales y lámparas de rayos infrarrojos para calentamiento de arriba modelo VISTA.

## PIZZA MODULAR



Modello  
Model  
Modèle  
Modell  
Modelo

Potenza  
Power  
Puissance  
Gesamtleistung  
Potencia

Tensione  
Tension  
Tension  
Spannung  
Tension

Temperatura  
Temperature  
Temperature  
Temperatur  
Temperatura

Potenza raggi infrarossi  
Infrared ray power  
Puissance des rayons infrarouges  
Leistung der infraroten Strahlen  
Potencia rayos infrarrojos

Potenza piastre in vetro ceramico  
Glass-ceramic plate power  
Puissance des plaques en céramique de verre  
Leistung der Platten aus Glaskeramik  
Potencia placas en vidrio-cerámica

Peso netto  
Net weight  
Poids net  
Nettogewicht  
Peso neto



PIZZA BASE



Watt 270



230v/1/50Hz



°C +30/+120

-



Kg 5,8

A		
AB	1/2 - COLD BOX	PAG. 24 - 25 - 26
<b>ABX 396</b>	1/2 - COLD BOX	PAG. 27
<b>ABX 506</b>	1/2 - COLD BOX	PAG. 27
<b>ABX 530</b>	1/2 - COLD BOX	PAG. 27
<b>ABX 610</b>	1/2 - COLD BOX	PAG. 27
<b>ABX 710</b>	1/2 - COLD BOX	PAG. 27
<b>ADE C</b>	13/1 - BANCHI HYPER	PAG. 275
<b>ADE M</b>	12/3 - BANCHI	PAG. 246
<b>ADE O</b>	12/3 - BANCHI	PAG. 254
<b>ADI C</b>	13/1 - BANCHI HYPER	PAG. 275
<b>ADI M</b>	12/3 - BANCHI	PAG. 246
<b>ADI O</b>	12/3 - BANCHI	PAG. 254
<b>AE</b>	7/3 - ECOLINE	PAG. 101 - 102 - 103
<b>AE COMBI</b>	7/3 - ECOLINE	PAG. 104 - 105
<b>APEX 400 FISH</b>	7/1 - SNACK	PAG. 93
<b>ALLU</b>	4/2 - MODERN BAR	PAG. 73
<b>AMERIKA</b>	9/5 - BANCOPIZZA	PAG. 173
<b>AN (Neutro)</b>	7/8 - NEUTRO	PAG. 126 a 128
<b>ANEX 400 NT</b>	7/1 - SNACK	PAG. 92
<b>APEX 400 PT</b>	7/1 - SNACK	PAG. 92
<b>ATE C</b>	13/1 - BANCHI HYPER	PAG. 272
<b>ATE M</b>	12/3 - BANCHI	PAG. 246
<b>ATE O</b>	12/3 - BANCHI	PAG. 254
<b>ATI C</b>	13/1 - BANCHI HYPER	PAG. 272
<b>ATI M</b>	12/3 - BANCHI	PAG. 246
<b>ATI O</b>	12/3 - BANCHI	PAG. 254
<b>AZZURRA 2-3</b>	11/2 - TAPAS&SUSHI	PAG. 207

B		
<b>BABY</b>	12/2 - MURALI	PAG. 228-229
<b>BABY INOX</b>	12/2 - MURALI	PAG. 228-229
<b>BABY WOOD</b>	12/2 - MURALI	PAG. 228-229
<b>BANCO PIZZA PC - P</b>	9/5 - BANCOPIZZA	PAG. 174 a 177
<b>BCG (Chiller)</b>	3/3 - CHILLER	PAG. 49
<b>BE - I (Chiller)</b>	3/3 - CHILLER	PAG. 52
<b>BEG (Chiller)</b>	3/3 - CHILLER	PAG. 50 - 51
<b>BM 1/1-150</b>	10/1 - ACCESS. CUCINA	PAG. 193
<b>BREAK 400-600</b>	5/1 - BREAK	PAG. 76 - 77
<b>BS NT - PTS</b>	7/12 - BIG STORE	PAG. 142 a 144

C		
<b>C 10 G</b>	1/1 - LITTLELINE	PAG. 11
<b>C 10 G SS</b>	1/1 - LITTLELINE	PAG. 11
<b>C 165 G</b>	1/1 - LITTLELINE	PAG. 8
<b>C 170 G BLACK</b>	2/2 - SOMELIERE	PAG. 44
<b>C 2 G</b>	1/1 - LITTLELINE	PAG. 8

<b>C 36 G</b>	1/1 - LITTLELINE	PAG. 6
<b>C 46 G</b>	1/1 - LITTLELINE	PAG. 6
<b>C 5 GM</b>	1/1 - LITTLELINE	PAG. 9
<b>C 61 G</b>	1/1 - LITTLELINE	PAG. 6
<b>C 8 G</b>	1/1 - LITTLELINE	PAG. 10
<b>C 8 G SS</b>	1/1 - LITTLELINE	PAG. 10
<b>C 85 G</b>	1/1 - LITTLELINE	PAG. 7
<b>CARGO</b>	7/4 - GASTROLINE	PAG. 115 - 116
<b>CASSETTIERA 2</b>	9/5 - BANCOPIZZA	PAG. 178
<b>CASSETTIERA 7</b>	9/5 - BANCOPIZZA	PAG. 178
<b>CBX - DELTA</b>	1/2 - COLD BOX	PAG. 18
<b>CBX</b>	1/2 - COLD BOX	PAG. 18
<b>CC 45</b>	2/2 - SOMELIERE	PAG. 42
<b>CC 48</b>	1/1 - LITTLELINE	PAG. 6
<b>CFKS 471 X</b>	1/1 - LITTLELINE	PAG. 16
<b>CFS 344 X</b>	1/1 - LITTLELINE	PAG. 15
<b>CHALLENGER</b>	13/3 - MURALI HYPER	PAG. 278-279
<b>CHALLENGER MAXI</b>	13/3 - MURALI HYPER	PAG. 278-279
<b>CHEF COLD</b>	11/3 - CHEF	PAG. 208
<b>CHEF DRY</b>	11/3 - CHEF	PAG. 210
<b>CHEF TURBO</b>	11/3 - CHEF	PAG. 209
<b>CLEAN DISH</b>	7/10 - WASH MASTER	PAG. 135 a 137
<b>CLEAN GLASS</b>	7/10 - WASH MASTER	PAG. 133 - 134
<b>CLEAN PAN</b>	7/10 - WASH MASTER	PAG. 138 - 139
<b>CLIPPER</b>	12/2 - MURALI	PAG. 226
<b>CREPES</b>	4/2 - MODERN BAR	PAG. 63
<b>CUSTOM CV-SG</b>	13/1 - BANCHI HYPER	PAG. 273
<b>CUSTOM SS-V SG</b>	13/1 - BANCHI HYPER	PAG. 274
<b>CUSTOM CASSA MCC 625</b>	13/1 - BANCHI HYPER	PAG. 274-275
<b>CUTTER 4 - 6</b>	10/1 - ACCESS. CUCINA	PAG. 188
<b>CVKS 681</b>	2/2 - SOMELIERE	PAG. 40
<b>CK - DELTA</b>	1/2 - COLD BOX	PAG. 23
<b>CK</b>	1/2 - COLD BOX	PAG. 23

D		
<b>DELICIOUS</b>	12/5 - DELICIOUS	PAG. 262
<b>DELICIOUS C</b>	12/5 - DELICIOUS	PAG. 262
<b>DELICIOUS SS</b>	12/5 - DELICIOUS	PAG. 262
<b>DELICIOUS Euronorm C</b>	12/5 - DELICIOUS	PAG. 263
<b>DISCOVERY</b>	12/2 - MURALI	PAG. 232
<b>DOLCE</b>	4/2 - MODERN BAR	PAG. 65

E		
<b>EASY</b>	12/2 - MURALI	PAG. 231
<b>EB</b>	3/2 - RAFFRED. DI FUSTI	PAG. 47
<b>EI</b>	7/9 - ICE MAKERS	PAG. 130
<b>EL</b>	1/2 - COLD BOX	PAG. 29

EUROLINE  
VINO  
BIRRA  
BAR  
MERCATI SPECIALI  
LABORATORI PASTICCERIA  
RISTORAZIONE  
FAST FOOD  
PIZZERIA  
CUCINA  
ESPOSIZIONE  
SUPERMERCATI  
HYPERMARKET

<b>ELBA</b>	12/8 - ATLANTIDE	PAG. 268-269
<b>EM-C 1100 Digit</b>	8/1 - FOOD SIMPATY	PAG. 152
<b>EM-S 1000 Digit</b>	8/1 - FOOD SIMPATY	PAG. 152
<b>EURONORM BASE - VISTA</b>	8/5 - HOTPLATE	PAG. 165
<b>EUROPA</b>	12/1 - ISLAND&MURALES	PAG. 222-223
<b>EXPO WINE</b>	2/1 - BANCOWINE	PAG. 38

✓ **F**

<b>F 165 G</b>	1/1 - LITTLELINE	PAG. 9
<b>F 45 GR</b>	1/1 - LITTLELINE	PAG. 7
<b>FASTFOOD</b>	9/5 - BANCOPIZZA	PAG. 172
<b>FI</b>	7/9 - ICE MAKERS	PAG. 129
<b>FI 13</b>	7/9 - ICE MAKERS	PAG. 129
<b>FIP</b>	7/9 - ICE MAKERS	PAG. 131
<b>FKG 311 S</b>	1/1 - LITTLELINE	PAG. 12
<b>FKG 370 S</b>	1/1 - LITTLELINE	PAG. 14
<b>FKG 371 S</b>	1/1 - LITTLELINE	PAG. 13
<b>FKG</b>	1/2 - COLD BOX	PAG. 17
<b>FKGR</b>	1/2 - COLD BOX	PAG. 17
<b>FMO</b>	8/1 - FOOD SIMPATY	PAG. 150 - 151
<b>FORNETTO PIZZA</b>	4/2 - MODERN BAR	PAG. 55
<b>FP 1</b>	9/8 - PIASTRE&FORNI	PAG. 185
<b>FP 1+1</b>	9/8 - PIASTRE&FORNI	PAG. 185
<b>FP 6</b>	9/8 - PIASTRE&FORNI	PAG. 186
<b>FP 6 BIS</b>	9/8 - PIASTRE&FORNI	PAG. 186
<b>FP 6+6</b>	9/8 - PIASTRE&FORNI	PAG. 186
<b>FP 6+6 BIS</b>	9/8 - PIASTRE&FORNI	PAG. 186
<b>FP 4</b>	9/8 - PIASTRE&FORNI	PAG. 186
<b>FP 4+4</b>	9/8 - PIASTRE&FORNI	PAG. 186
<b>FRAPPE'</b>	4/2 - MODERN BAR	PAG. 70
<b>FRESH YOGURT</b>	4/1 - EXPO BAR	PAG. 54
<b>FRULLATORE TORNADO</b>	4/2 - MODERN BAR	PAG. 70
<b>FRULLATORE TWISTER</b>	4/2 - MODERN BAR	PAG. 69

✓ **G**

<b>GASTRONORM BASE - VISTA</b>	8/5 - HOTPLATE	PAG. 165
<b>GASTROSERVICE COLD</b>	11/1 - GASTROSERVICE	PAG. 196 a 199
<b>GASTROSERVICE DRY</b>	11/1 - GASTROSERVICE	PAG. 196 a 199
<b>GEMINI</b>	8/1 - FOOD SIMPATY	PAG. 150
<b>GENESIS</b>	12/2 - MURALI	PAG. 234
<b>GLX 700</b>	7/4 - GASTROLINE	PAG. 108
<b>GLX 1400</b>	7/4 - GASTROLINE	PAG. 109
<b>GLX FISH</b>	7/4 - GASTROLINE	PAG. 110
<b>GLX COMBI</b>	7/4 - GASTROLINE	PAG. 111
<b>GLX PTS TOP - ALZ</b>	7/4 - GASTROLINE	PAG. 112
<b>GLX NT TOP - ALZ</b>	7/4 - GASTROLINE	PAG. 113
<b>GONDOLA 2V</b>	13/2 - ISOLE HYPER	PAG. 276-277

<b>GONDOLA EXPO</b>	13/2 - ISOLE HYPER	PAG. 276-277
<b>GONDOLA TOP</b>	13/2 - ISOLE HYPER	PAG. 276-277
<b>GONDOLA WALL</b>	13/2 - ISOLE HYPER	PAG. 276-277
<b>GRANSUSHI 3 GN 1/1</b>	11/2 - TAPAS&SUSHI	PAG. 206
<b>GRANTAPAS 3 GN 1/1 - 2</b>	11/2 - TAPAS&SUSHI	PAG. 202
<b>GRANTAPAS 3 GN 1/1 - 2 - SPLIT</b>	11/2 - TAPAS&SUSHI	PAG. 202
<b>GRANTAPAS 3 GN 1/1 BM</b>	11/2 - TAPAS&SUSHI	PAG. 204
<b>GRATIN</b>	4/2 - MODERN BAR	PAG. 59

✓ **H**

<b>HIELO</b>	4/2 - MODERN BAR	PAG. 71
<b>HP 1500 - 2500</b>	4/2 - MODERN BAR	PAG. 56

✓ **I**

<b>ICEBERG</b>	12/1 - ISLAND&MURALES	PAG. 218
<b>IGLOO</b>	12/1 - ISLAND&MURALES	PAG. 216
<b>IKG</b>	1/2 - COLD BOX	PAG. 20
<b>IKG JUMBO</b>	12/1 - ISLAND&MURALES	PAG. 214-215
<b>IKGR</b>	1/2 - COLD BOX	PAG. 20
<b>IL CIOCCO</b>	4/2 - MODERN BAR	PAG. 63
<b>IMPASTA</b>	9/1 - IMPASTATRICI	PAG. 168

✓ **K**

<b>KT 350</b>	7/2 - KITCHEN	PAG. 95 - 96
<b>KTMB PT GLASS</b>	7/2 - KITCHEN	PAG. 97
<b>KTMB PTS - NT</b>	7/2 - KITCHEN	PAG. 98
<b>KTMB COMBI 1.2</b>	7/2 - KITCHEN	PAG. 99
<b>KTMB COMBI 3</b>	7/2 - KITCHEN	PAG. 100

✓ **L**

<b>L 380 - 450</b>	4/2 - MODERN BAR	PAG. 74
<b>LAMPO 2 - 3</b>	2/1 - BANCOWINE	PAG. 39
<b>LC 260 - 300 - 400</b>	10/1 - ACCESS. CUCINA	PAG. 193
<b>LIEVAMATIC 700 NT - PTS</b>	7/5 - FERMALIEVITATORI	PAG. 117
<b>LIEVITA - N</b>	8/3 - SUN SIMPATY	PAG. 161
<b>LIEVITA - S</b>	8/3 - SUN SIMPATY	PAG. 161

✓ **M**

<b>MAJESTIC 45 AE</b>	5/2 - POCKET BAR	PAG. 80
<b>MASTER 45 AE</b>	5/2 - POCKET BAR	PAG. 80
<b>MAXIMA C-BM</b>	12/3 - BANCHI	PAG. 244
<b>MAXIMA CS - CV</b>	12/3 - BANCHI	PAG. 240-241
<b>MAXIMA DS - DV</b>	12/3 - BANCHI	PAG. 240-241
<b>MAXIMA SS-V</b>	12/3 - BANCHI	PAG. 243
<b>MAXIMA HOT</b>	12/3 - BANCHI	PAG. 245
<b>MB 45</b>	5/3 - TRAVELCOLD	PAG. 81
<b>MB 60</b>	5/3 - TRAVELCOLD	PAG. 81

<b>MCS</b>	7/12 - BIG STORE	PAG. 147
<b>MDA</b>	7/12 - BIG STORE	PAG. 145
<b>MDAE</b>	7/12 - BIG STORE	PAG. 146
<b>MEDIKA 300</b>	5/5 - MEDIKAL	PAG. 83
<b>MEDIKA 380</b>	5/5 - MEDIKAL	PAG. 83
<b>MEDIKA 400</b>	5/5 - MEDIKAL	PAG. 84
<b>MEGA 3 - 6</b>	4/2 - MODERN BAR	PAG. 56
<b>MESCOLA 7</b>	10/1 - ACCESS. CUCINA	PAG. 190
<b>MINI AE</b>	5/2 - POCKET BAR	PAG. 78 - 79
<b>MITILI</b>	12/8 - ATLANTIDE	PAG. 268-269
<b>MIXER 430 - 550</b>	10/1 - ACCESS. CUCINA	PAG. 191
<b>MLV</b>	7/12 - BIG STORE	PAG. 148
<b>MCM - BANCO CASSA</b>	12/3 - BANCHI	PAG. 246
<b>MCO - BANCO CASSA</b>	12/3 - BANCHI	PAG. 254
<b>MS 20 - 24</b>	7/11 - MULTISPAZIO	PAG. 140 - 141
<b>MULTI GN - PROF</b>	4/2 - MODERN BAR	PAG. 60 - 61

**N**

<b>NAXOS</b>	8/3 - SUN SIMPATY	PAG. 160
<b>NEUTRO</b>	7/8 - NEUTRO	PAG. 126 a 128
<b>NV</b>	7/9 - ICE MAKERS	PAG. 130

**O**

<b>OCEANUS</b>	12/7 - OCEANUS	PAG. 267
<b>OPTIMA BM</b>	12/3 - BANCHI	PAG. 252
<b>OPTIMA CV</b>	12/3 - BANCHI	PAG. 250-251
<b>OPTIMA SS-V</b>	12/3 - BANCHI	PAG. 250-251
<b>OPTIMA HOT</b>	12/3 - BANCHI	PAG. 253
<b>ORION</b>	8/3 - SUN SIMPATY	PAG. 159

**P**

<b>PANCHO X</b>	4/2 - MODERN BAR	PAG. 62
<b>PANCHO COMBI</b>	4/2 - MODERN BAR	PAG. 62
<b>PE 60 - 90</b>	8/4 - FOOD SPRINTER	PAG. 163
<b>PF 2</b>	8/4 - FOOD SPRINTER	PAG. 162
<b>PIZZA</b>	9/6 - TAVOLI	PAG. 179 a 182
<b>PIZZA 500 PT</b>	9/3 - ARMADI	PAG. 170
<b>PIZZA BASE HOT PLATE</b>	9/8 - PIASTRE&FORNI	PAG. 166
<b>PL 400</b>	1/3 - PENNY LINE	PAG. 31 - 32
<b>PL 500</b>	1/3 - PENNY LINE	PAG. 33
<b>PL 600</b>	1/3 - PENNY LINE	PAG. 34
<b>PLANCHA VULCANO</b>	8/2 - VULCANO	PAG. 155
<b>PLANET</b>	11/2 - TAPAS&SUSHI	PAG. 203 - 205
<b>PM 1 - 2</b>	8/4 - FOOD SPRINTER	PAG. 162
<b>PORTACOOOL</b>	5/3 - TRAVELCOLD	PAG. 81
<b>POS</b>	12/1 - ISLAND&MURALES	PAG. 212
<b>PREMIER</b>	12/2 - MURALI	PAG. 236-237

<b>PROMOXION 130 NT - PT</b>	12/1 - ISLAND&MURALES	PAG. 217
<b>PRONTO PIZZA</b>	4/2 - MODERN BAR	PAG. 55
<b>PRONTO PIZZA BIG</b>	4/2 - MODERN BAR	PAG. 55
<b>PSS 60 - 90</b>	8/4 - FOOD SPRINTER	PAG. 164
<b>PUNTO 1000</b>	12/1 - ISLAND&MURALES	PAG. 213
<b>PUNTO 600</b>	12/1 - ISLAND&MURALES	PAG. 212
<b>PUNTO 700</b>	12/1 - ISLAND&MURALES	PAG. 213

**Q**

<b>QUICKLY 1200 - 1600</b>	7/4 - GASTROLINE	PAG. 114
----------------------------	------------------	----------

**R**

<b>RB 300 - 400</b>	1/2 - COLD BOX	PAG. 19
<b>REFRIBIT</b>	4/2 - MODERN BAR	PAG. 68
<b>REP 1 - 2</b>	5/4 - SMALTIMENTO	PAG. 82
<b>RFB</b>	3/2 - RAFFRED. DI FUSTI	PAG. 48
<b>RIBALTA</b>	7/9 - ICE MAKERS	PAG. 132
<b>RISERVA</b>	7/9 - ICE MAKERS	PAG. 131

**S**

<b>SALAD</b>	7/7 - SALADETTES	PAG. 122 a 125
<b>SCA</b>	7/12 - BIG STORE	PAG. 142
<b>SCAGLIA 250 - 500</b>	7/9 - ICE MAKERS	PAG. 132
<b>SCHIACCIA 35 - 50</b>	9/4 - SCHIACCIATRICI	PAG. 171
<b>SF</b>	7/6 - SHOCKFROSTER	PAG. 120-121
<b>SF 2/3.7-5</b>	7/6 - SHOCKFROSTER	PAG. 120
<b>SFILA M - T</b>	10/1 - ACCESS. CUCINA	PAG. 190
<b>SHOPPING COLD</b>	12/6 - SHOPPING	PAG. 264-265
<b>SHOPPING DRY</b>	12/6 - SHOPPING	PAG. 266
<b>SIRIO</b>	8/3 - SUN SIMPATY	PAG. 158
<b>SKY</b>	12/1 - ISLAND&MURALES	PAG. 219
<b>SKY MASTER</b>	12/1 - ISLAND&MURALES	PAG. 219
<b>SLX PT TOP - ALZ</b>	6/2 - TAVOLI SWETTLINE	PAG. 90
<b>SLX (Armadi)</b>	6/1 - ARMADI SWEETLINE	PAG. 87 - 88 - 89
<b>SLXE 500 GLASS</b>	6/1 - ARMADI SWEETLINE	PAG. 86
<b>SLXE 500 NT</b>	6/1 - ARMADI SWEETLINE	PAG. 86
<b>SLXE 500 PTS</b>	6/1 - ARMADI SWEETLINE	PAG. 86
<b>SMART CS - DS</b>	12/3 - BANCHI	PAG. 238-239
<b>SMART CV - DV</b>	12/3 - BANCHI	PAG. 238-239
<b>SP138 - SP238</b>	10/2 - SCALDA PIATTI	PAG. 194
<b>SP</b>	9/7 - SOVRASTRUTTURE	PAG. 183 - 184
<b>SPACE</b>	12/2 - MURALI	PAG. 233
<b>SPD</b>	9/7 - SOVRASTRUTTURE	PAG. 183 - 184
<b>SPIO</b>	12/2 - MURALI	PAG. 225
<b>SPIO WOOD</b>	12/2 - MURALI	PAG. 225
<b>SPREMIAGRUMI</b>	4/2 - MODERN BAR	PAG. 72
<b>STAR</b>	4/2 - MODERN BAR	PAG. 57 - 58

<b>STENDI 30 - 40</b>	9/2 - STENDITRICI	PAG. 169
<b>STENDI 30 SFO</b>	9/2 - STENDITRICI	PAG. 169
<b>STOCK PT</b>	1/4 - STOCK	PAG. 35
<b>STOCK PTX</b>	1/4 - STOCK	PAG. 35
<b>STONE 190 NT - 250 NT</b>	13/3 - MURALI HYPER	PAG. 281
<b>STORAGE</b>	7/9 - ICE MAKERS	PAG. 132
<b>SUPER</b>	12/4 - SUPER	PAG. 260
<b>SUPER Euronorm C</b>	12/4 - SUPER	PAG. 261
<b>SUSHI</b>	11/2 - TAPAS&SUSHI	PAG. 206
<b>SZ</b>	1/2 - COLD BOX	PAG. 28

**T**

<b>TAGLIAVERDURE M - T</b>	10/1 - ACCESS. CUCINA	PAG. 189
<b>TAPAS</b>	11/2 - TAPAS&SUSHI	PAG. 200 a 204
<b>TEMPANO</b>	1/3 - PENNY LINE	PAG. 30
<b>TERMOLAT</b>	4/2 - MODERN BAR	PAG. 64
<b>TOASTER TURBO</b>	4/2 - MODERN BAR	PAG. 59
<b>TORNADO</b>	4/2 - MODERN BAR	PAG. 70
<b>TPEX PT ALZ - TOP SG</b>	7/1 - SNACK	PAG. 94
<b>TPEX PT</b>	7/1 - SNACK	PAG. 94
<b>TRICAR</b>	10/1 - ACCESS. CUCINA	PAG. 192
<b>TRIGRA</b>	10/1 - ACCESS. CUCINA	PAG. 192
<b>TRITAGHIACCIO</b>	4/2 - MODERN BAR	PAG. 71
<b>TSC PTS/NT - TOP/ALZ</b>	7/3 - ECOLINE	PAG. 106
<b>TSC PTS/NT - TOP/ALZ SG</b>	7/3 - ECOLINE	PAG. 107
<b>TURBINE INOX</b>	4/2 - MODERN BAR	PAG. 73
<b>TWISTER</b>	4/2 - MODERN BAR	PAG. 69

**U**

<b>ULISSE</b>	12/2 - MURALI	PAG. 230
<b>ULISSE INOX</b>	12/2 - MURALI	PAG. 230
<b>UNIVERSAL</b>	12/2 - MURALI	PAG. 235

**V**

<b>V - 30 - 100 - 200</b>	3/1 - DISTRIBUTORI	PAG. 46
<b>V 1 - 2</b>	4/2 - MODERN BAR	PAG. 67
<b>VCI</b>	1/2 - COLD BOX	PAG. 21
<b>VDA</b>	4/2 - MODERN BAR	PAG. 67
<b>VEGA EM</b>	8/1 - FOOD SIMPATY	PAG. 152
<b>VETRINETTA</b>	4/2 - MODERN BAR	PAG. 66
<b>VKG 571 BLACK</b>	2/2 - SOMELIERE	PAG. 43
<b>VKG 581 G</b>	2/2 - SOMELIERE	PAG. 41
<b>VLC</b>	1/2 - COLD BOX	PAG. 22
<b>VODKA 4 - 6</b>	4/1 - EXPO BAR	PAG. 54
<b>VORTICE</b>	4/2 - MODERN BAR	PAG. 68
<b>VOYAGER 200 COMBI</b>	12/1 - ISLAND&MURALES	PAG. 224
<b>VOYAGER 200 COMBI SPECIAL</b>	12/1 - ISLAND&MURALES	PAG. 224
<b>VOYAGER 200 NT - PT</b>	12/1 - ISLAND&MURALES	PAG. 224
<b>VULCANO</b>	8/2 - VULCANO	PAG. 153 a 156
<b>VULCANO MODULO</b>	8/2 - VULCANO	PAG. 157
<b>VULCANO WOK</b>	8/2 - VULCANO	PAG. 155

**W**

<b>WINE CONSOLE 6 - 8</b>	2/1 - BANCOWINE	PAG. 38
<b>WLK PT - NT</b>	1/5 - WALKING COOLER	PAG. 36

**NEWS 2008**

IL COSTRUTTORE SI RISERVA IL DIRITTO DI APPORTARE MODIFICHE DI MATERIALI E DI MODELLI SENZA PREAVVISO. I PESI, LE MISURE, ECC., SONO SEMPLICEMENTE FORNITI A TITOLO INDICATIVO E NON IMPEGNANO IL COSTRUTTORE. • WE RESERVE THE RIGHT TO MAKE CHANGES EITHER IN THE MATERIALS USED OR IN THE MODELS WITHOUT NOTICE. WEIGHTS, DIMENSIONS ETC. ARE GIVEN PURELY AS AN INDICATION AND THEY DO NOT ENGAGE THE MANUFACTURER. • LE CONSTRUCTEUR SE RÉSERVE LE DROIT D'APPORTER TOUTES MODIFICATIONS UTILES SUR LES COMPOSANTS ET LES MODELES SANS PRÉAVIS. LES POIDS, LES DIMENSIONS CARACTÉRISTIQUES SONT SIMPLEMENT FOURNIES A TITRE INDICATIF ET N'ENGAGENT PAS LE CONSTRUCTEUR. • DIE HERSTELLERFIRMA BEHAHLT SICH DAS RECHT VOR, OHNE VORHERIGE BENACHRICHTIGUNG AN MATERIAL UND AUSFUEHRUNG AENDERUNGEN VORZUNEHMEN. DIE GEWICHTE UND MASSE SIND HINWEISE UND VERPFLICHTEN NICHT DEN HERSTELLER. • EL CONSTRUCTOR SE RESERVA EL DERECHO DE INTRODUCIR MODIFICACIONES EN LOS MATERIALES Y MODELOS SIN PREAVISO. EL PESO, MEDIDAS, ETC. SON DADAS SIMPLEMENTE A TITULO INFORMATIVO, SIN QUE ESTO OBLIGUE AL CONSTRUCTOR.

# NOTE

HYPERMARKET

SUPERMERCATI

ESPOSIZIONE

CUCINA

PIZZERIA

FAST FOOD

RISTORAZIONE

LABORATORI  
PASTICCERIA

MERCATI  
SPECIALI

BAR

BIRRA

VINO

EUROLINE

HYPERMARKET

SUPERMERCATI

ESPOSIZIONE

CUCINA

PIZZERIA

FAST FOOD

RISTORAZIONE

LABORATORI  
PASTICCERIA

MERCATI  
SPECIALI

BAR

BIRRA

VINO

EUROLINE

*Note*





COLD  
ENGINEERING  
**TECFRIGO**



Organizzazione con Sistema  
di Gestione certificato  
Company with Management  
System certified

ISO 9001:2000

**SINCERT**